

CORNISH HUSH MINE. AE 52.

In the period 31. 5. 72. to 30. 9. 72., 21.1 m. of rehabilitation and 17.0 m. of driving were carried out at this mine.

The work of rehabilitating the level was seriously delayed by open stopes below the level, which necessitated the laying of stulls to support the rail track, and subsequent backfilling of these stopes. By early June the approximate position of the Main Air Shaft was reached. This shaft had been located and opened on the surface but conditions in the level, with continual runs of loose material made it impossible to reopen the level beneath the shaft. As a result a bypass drift (No. 2) was started some 25 m. back from the estimated position of the shaft. This drift had been driven for 17.0 m. up to September 30th 1972.

Little geological information is available for the sections of the old mine that have been reopened. This is the result of the original stone arching concealing the level walls. However, where bypass levels have been driven they have been in the massive coarse grained and cross bedded grits of the Low Grit Sill.

The accompanying plan shows the positions of the bypass levels and such new geological data as is available.



G. HUGHES.

Swiss Aluminium Mining (U.K.) Ltd.

MME 1/A352/4

Little Applestone Exploration Project

Progress Report : January 1975 to 4th July 1975

Progress during the latter part of 1974 was slow due to the poor state of the old workings encountered. As a result of this, a bypass drift was being driven during the first four months of 1975. This drift was driven through sandstones and grits with occasional argillaceous siltstones. The ground was generally good but with occasional broken and blocky patches at joint foci. Little ground support was necessary.

The only mineralization encountered was a small cross vein striking at 81° bearing some 70 to 100 mm of quartz and with some silicification of the surrounding country rock. Although there was some steepening of bedding in the area adjacent to this vein, no major displacement was evident, the apparent down throw to the north, being less than one metre.

In early May, shortly after intersecting the cross vein, the bypass drift was turned into the old level again and this level was cleared for a further 27 metres before the suspension of work on 4th July 1975.

This suspension is the result of a concentration of all available manpower at Cambokeels and Stanhopeburn mines, in an effort to bring them into production at the earliest possible date.

As soon as these mines are in production exploration at this and other sites can be recommenced

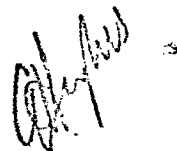

G. Hughes

12th August 1976

Appendix.

Brief notes on the Principles of the Geophysical Methods referred to in this Report.

(i) The A.B.E.M. Moving-Source-Receiver Method.

The A.B.E.M. E.M. Gun used during the present survey consists of a transmitter and a receiver combined with an A.C. compensator. The transmitter, which consists of a transistor oscillator connected to a coil wound on a ferrite core having a vertical axis, sends electromagnetic waves into the ground. These waves induce electric currents into any subsurface conductor, a secondary magnetic field is then produced which distorts the primary field. The basis of the method is to measure accurately these distortions or anomalies at the receiver.

The resultant magnetic field will differ in both phase and amplitude from the magnetic field which would be received at the receiver if no conductors were in the vicinity. In the A.B.E.M. Gun the results are not expressed in terms of amplitude and phase but as real and imaginary components of the resultant field. It can be shown that the resultant magnetic field is composed of two waves of the same frequency but of different amplitudes and out of phase with each other. One of the waves is in phase with the primary field, the other wave being 90° out of phase with it. The amplitudes of these two waves are known as the real and imaginary components, or sometimes termed in-phase and out-of-phase components. The A.C. compensator built into the receiver in the A.B.E.M. system, is the unit which measures the real and imaginary components. When no conductors are present in the vicinity the real component has a nominal reading of 100% and the imaginary component 0%. During the survey of a particular area the transmitter

and receiver are kept a fixed distance apart in line with the traverse direction and readings are taken at short intervals. The readings refer to a point midway between the transmitter and receiver. The traverse direction should ideally be at right angles to the probable strike of veins but in practice $\pm 30^\circ$ off-strike would be quite acceptable.

When the transmitter-receiver combination is taken across a vertical conducting vein the real and imaginary components of the magnetic field acting on the receiver show characteristic variations. A typical response is shown in Fig. 1

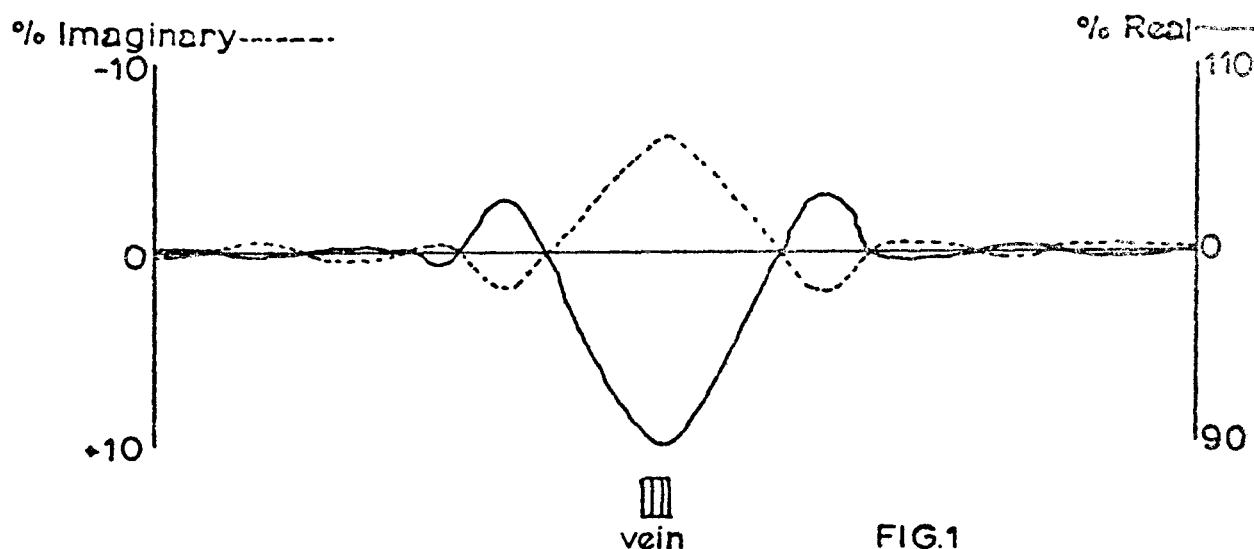

When the transmitter and receiver are both on the same side of the vein the vertical component of the secondary magnetic field will be the same direction as the primary field and therefore the amplitude of both the real and imaginary components is increased. Immediately above the vein the secondary magnetic field has no vertical component, when the receiver is in this position it receives the primary field alone i.e. 100% for real, 0% for imaginary. When the transmitter is above the vein no lines of magnetic force cut the conductor and therefore the field at the receiver is again the primary field. Therefore it is seen that in theory the distance between the two points when the field

at the receiver is the primary field, is the same as the separation between transmitter and receiver. In practice this distance is usually somewhat larger than the coil spacing, the excess over the coil spacing gives a rough indication of the width of the anomalous zone.

When the transmitter-receiver combination is astride the vein the secondary field is in opposition to the primary field and the amplitudes of the real and imaginary components are reduced.

Interpretation of the curves and factors which affect them are discussed below. The ratio of real to imaginary components at the anomaly gives an indication of the conductivity of the subsurface conductor causing it. A good conductor gives a large real and a small imaginary component, a bad conductor gives a relatively large imaginary but a small real component, whereas a medium conductor has both components fairly large.

The relative sizes of the two positive peaks on each side of the main anomaly give an indication of which way the vein is dipping. The peak on the down-dip side is the larger of the two.

Measurements can be made at two fixed frequencies (880 c/s and 3520 c/s) with the A.E.M. Gun. In general the size of an anomaly found with the higher frequency will be smaller when using the lower frequency. The use of measurements at two frequencies may be of value in distinguishing between anomalies due to near-surface overburden effects, local geology etc., and deep-seated conductors.

However the applicability of this procedure for the Northern Pennines has not yet been fully evaluated.

Measurements may be made using different coil separations the depth penetration of the method being approximately the same as the coil separation. Theoretically overburden anomalies should increase in size with a smaller coil separation whereas anomalies due to deep-seated veins will tend to stay the same or decrease in size. This factor has to be fully evaluated for the Northern Pennines.

Anomalies should ideally have a positive peak on each side, with a steady rise and fall to some maximum negative value (for the real component "positive" means a value above 100, "negative" is a value below 100) and these are the features sought when scanning the plotted curves of an A.T. survey.

Numerically the resistivity of a material can be defined as being equal to the resistance (in ohms) between two opposite faces of a cube of the material of side one metre. The resistivity method of geophysical prospecting consists of taking resistivity measurements along a traverse line. Where suitable conductivity contrasts exist, veins, fault zones etc. can be detected.

Resistivity measurements are made by passing electric current into the ground via two electrodes and measuring the resulting potential difference, caused by the resistance of the ground to this current, across a further pair of electrodes. There are a number of different electrode arrays that can be used by from previous work in the Department of Mining and Mineral Sciences (W.C. Nightman Ph.D Thesis 1971 University of Leeds) the one found to be most suitable for detecting fluorspar veins in Derbyshire was that devised by P. Wenner in 1915. The Wenner array consists of four equally spaced electrodes, current being passed through the outer pair, the inner pair being used to measure the resulting potential difference.

Considering the definition of resistivity, and potential theory, the resistivity for this array can be shown to be:-
resistivity = $2\pi a \frac{V}{I}$ ohm-metres:-

where a = distance between electrodes (in metres)

V = potential drop across inner pair of electrodes
(in volts)

I = current passing through outer pair of electrodes.
(in amps)

The equipment in use for the present survey is the A.B.E.M. Terrameter. This measures the function $\frac{V}{I}$ directly, giving a resistance reading in ohms. In order to overcome the effects of stray electric currents and polarisation of the electrodes it operates at a frequency of 4 c/s.

The electrode array may be aligned parallel to the strike of the feature or perpendicular to it. These two orientations are normally defined as values of P, P= 0.5 for the first case and P = 0 for the second. Again from previous work in Derbyshire it was found that the system P = 0.5 gave the simplest anomalies and was more convenient for field operations. As with the E.M and V.L.P. E.M. work the traverse direction should ideally be at

right angles to the general direction of strike of veins in the area being surveyed.

Resistance measurements for different electrode spacings can conveniently be taken with the use of multicore cables and take-off points. For the present survey spacings of 12, 24 and 32 metres were used.

The depth penetration of the method depends on a number of factors. For a given electrode spacing the depth penetration will be dependent on the resistivities of the rocks beneath. A layer of highly conductive overburden will greatly reduce the penetration. The depth penetration of the method is increased with increasing electrode separation but there are limitations to the maximum spacing that can be used. For a given power source to pass current into the ground, at very large spacings the accuracy of measuring very small resistance values is greatly reduced.

(iii) The V.L.F. E.M. Method.

The Very Low Frequency (V.L.F.) E.M. method relies on radio signals from government communication stations for the primary signal. Thus the equipment basically consists of a sensitive radio receiver tuned to the V.L.F. band (approximately 15-20 Kc/s).

V.L.F. transmitting stations have a vertical aerial, the aerial current is therefore vertical and creates a concentric horizontal magnetic field around it. When these magnetic fields meet a conducting orebody, secondary magnetic fields are set up which have vertical components associated with them. The V.L.F. M-16 receiver used for this survey measures the in-phase (real) and out-of-phase (quadrature) components of the vertical magnetic field vector at the receiver.

The receiver itself has two inputs with two receiving coils built into the instrument, one coil having a vertical axis and the other being horizontal. The radio signal received by the vertical coil is first nulled by tilting the instrument. The remaining signal in this coil is then balanced out by a measured percentage of the signal received by the horizontal coil, after this has been shifted in phase by 90°.

It can be shown mathematically that if the secondary signals are small compared to the primary horizontal field, the mechanical tilt angle of the instrument is a measure of the vertical real component, and the compensation signal from the horizontal coil is a measure of the quadrature component.

At any point distant from a transmitting station the magnetic field is at right angles to the direction in which the station lies from that point and therefore a station must be selected that gives a field approximately at right angles to the strike of the ore bodies of local geology. The strike should therefore point to the transmitter but variations of $\pm 45^\circ$ from this could be acceptable depending on the conductivity of the vein.

In the Northern Peninsines, the only useable station for E-W striking veins was found to be NAA (Cutler, Maine) whereas for NW-SE veins both NAA and GBR (Rugby) could be used.

number of station can be used. Two units can be mounted in the instrument at one time, and, together with a change-over switch, enable readings for two station to be taken during a traverse.

When measurements are taken with the V.L.F. receiver on a traverse over a conducting vein, the real and quadrature components of the vertical magnetic field show characteristic variations. A typical response is shown in Fig. 2

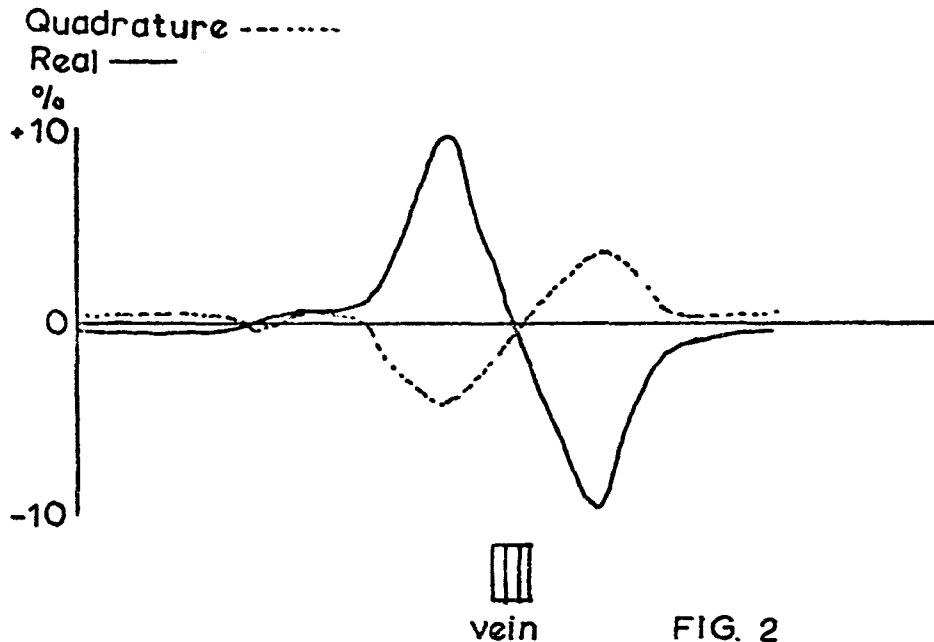

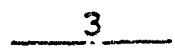



FIG. 2

The primary magnetic field is horizontal, conductive zones such as veins will add vertical components and the total magnetic field will be tilted locally on both sides. The EM-16 is so calibrated that when approaching a conductor the readings are positive for the real component. The quadrature component for a good conductor will be as if Fig. 2. For a poor conductor the quadrature component will follow the real component polarity.

In general when searching V.L.F. curves for anomalies, cross-overs for the real component should be looked for, but local geological conditions may modify the curve and inflexions may give a clue to the position of an anomaly. For the real component the larger peak gives an indication of the down-dip side of the conductor.

Quantitative techniques of interpretation in V.L.F. E.M. prospecting are still in an early stage of development.

FIG. 8
Traverse Lines and E.M.
Anomalies.
Middleton Common Survey.

-  TRAVERSE LINE
-  ANOMALY
-  DOUBTFUL ANOMALY
-  PEG WITH NUMBER

SCALE: 6" TO ONE MILE

Imaginary%

NE.
Real %

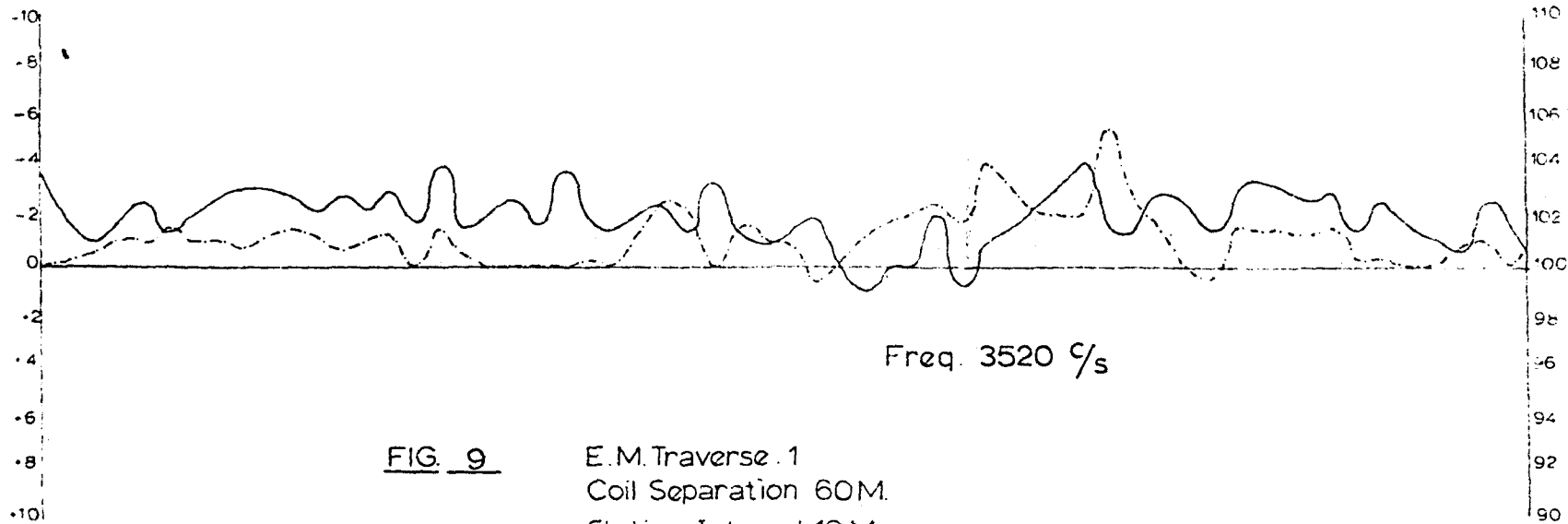
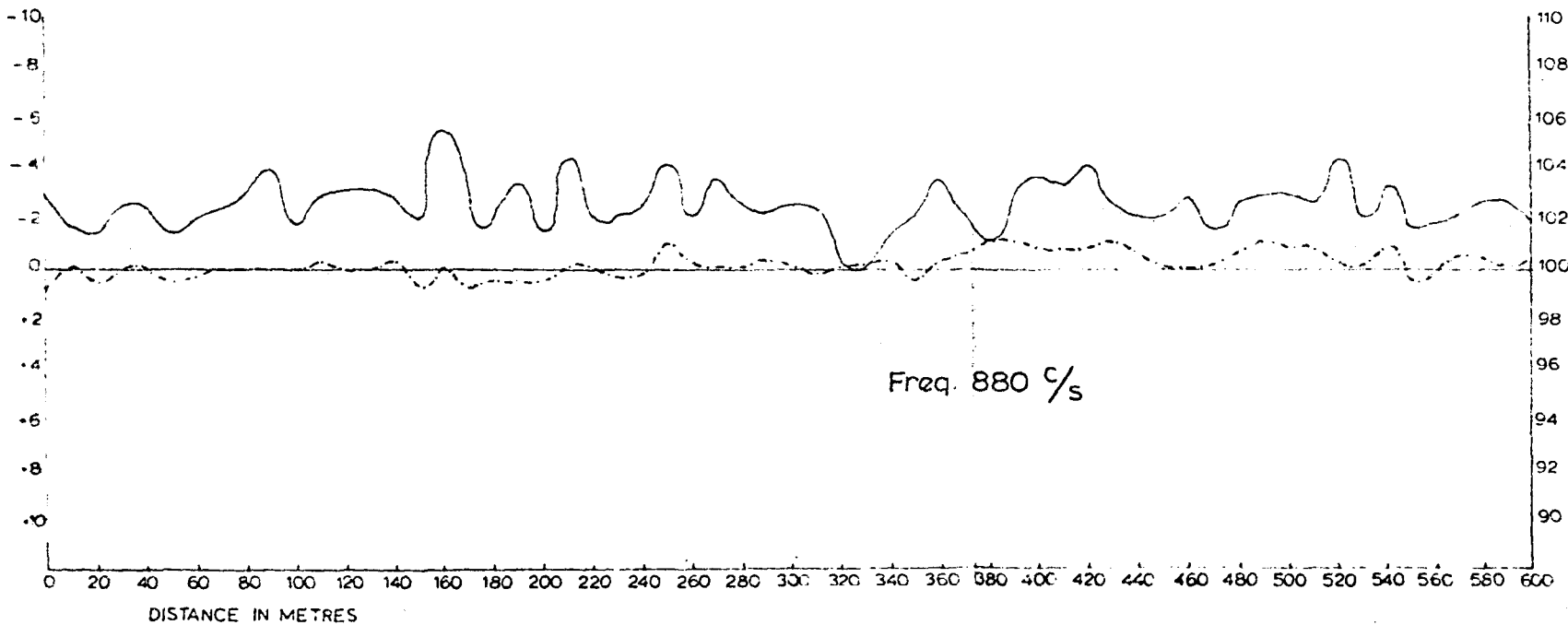

FIG. 9

E.M. Traverse .1
 Coil Separation 60M.
 Station Interval 10M.
 Real Component —
 Imaginary Component - - -



S.W.
Imaginary%

N.E.
Real%

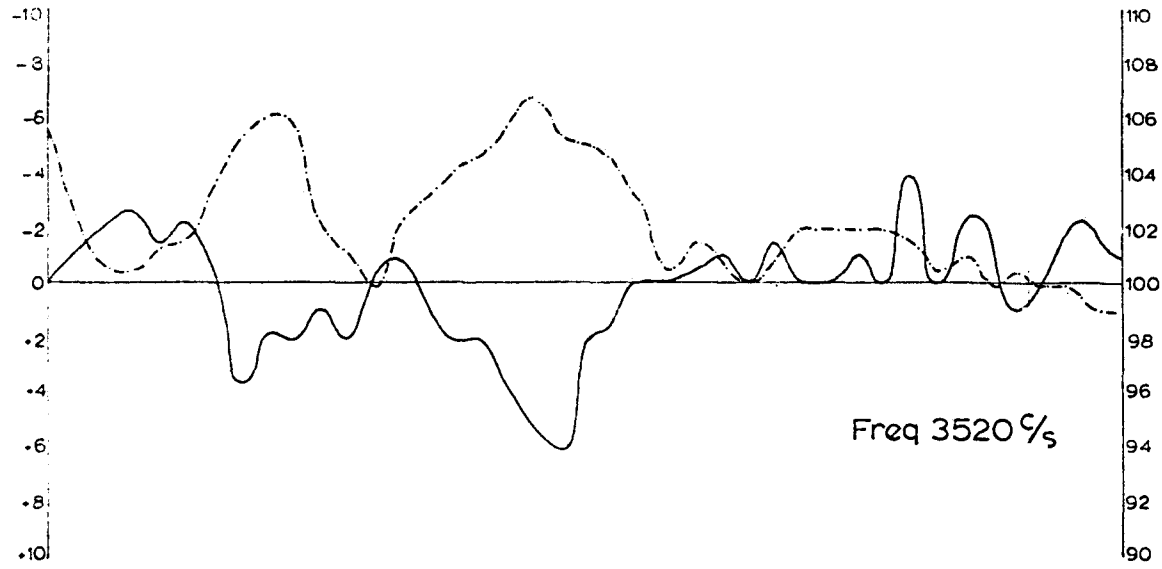
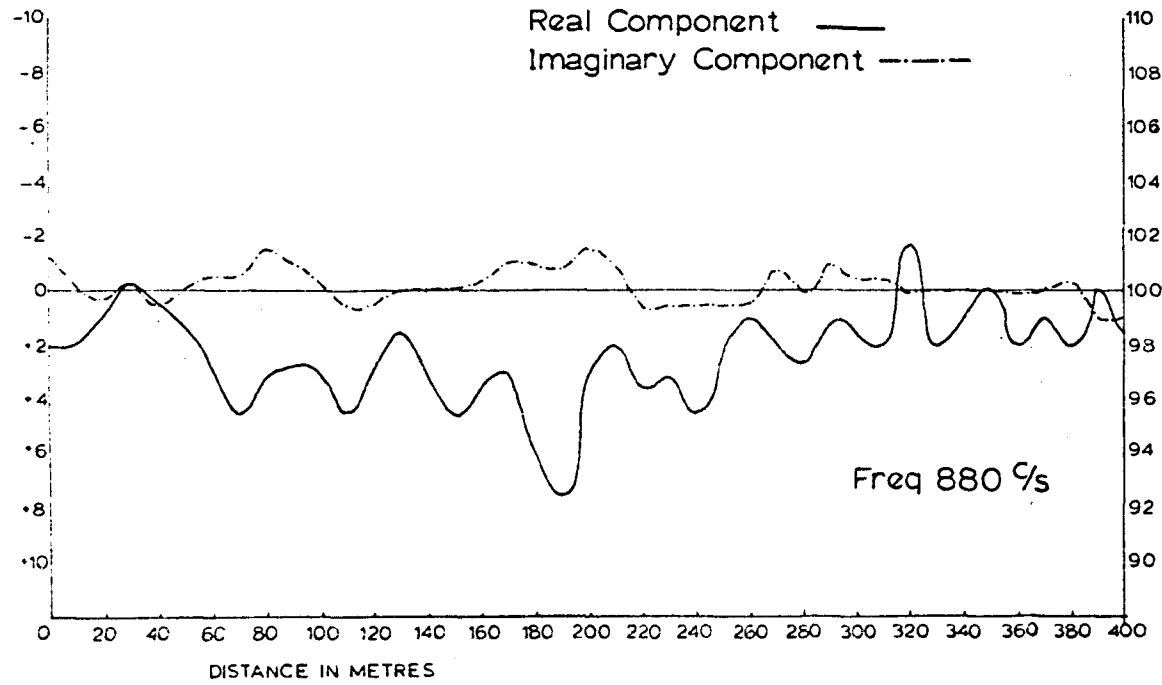

FIG. 10

E. M. Traverse 2
Coil Separation 60M.
Station Interval 10 M.

Real Component —
Imaginary Component - - -



Freq 880 %s

DISTANCE IN METRES

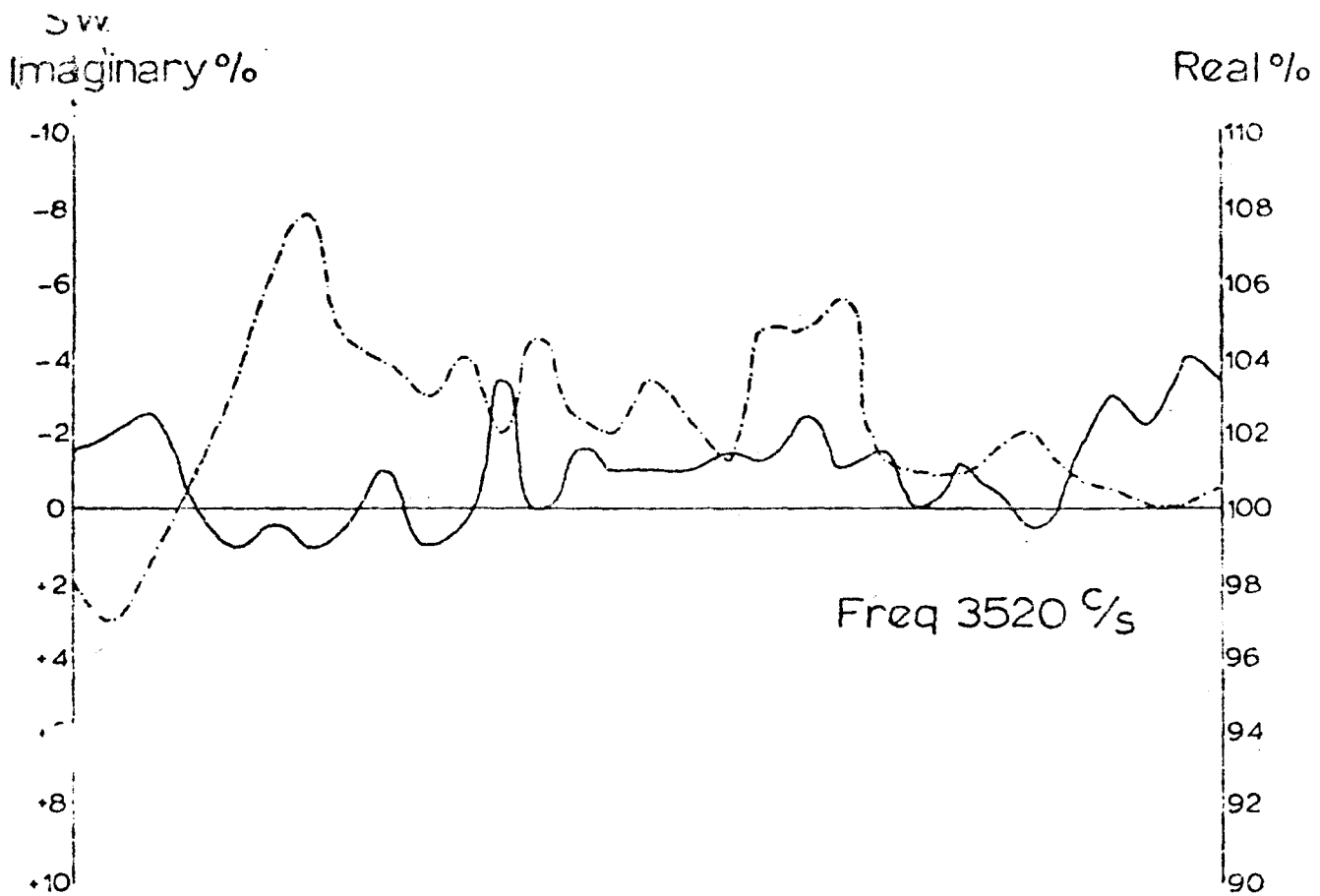
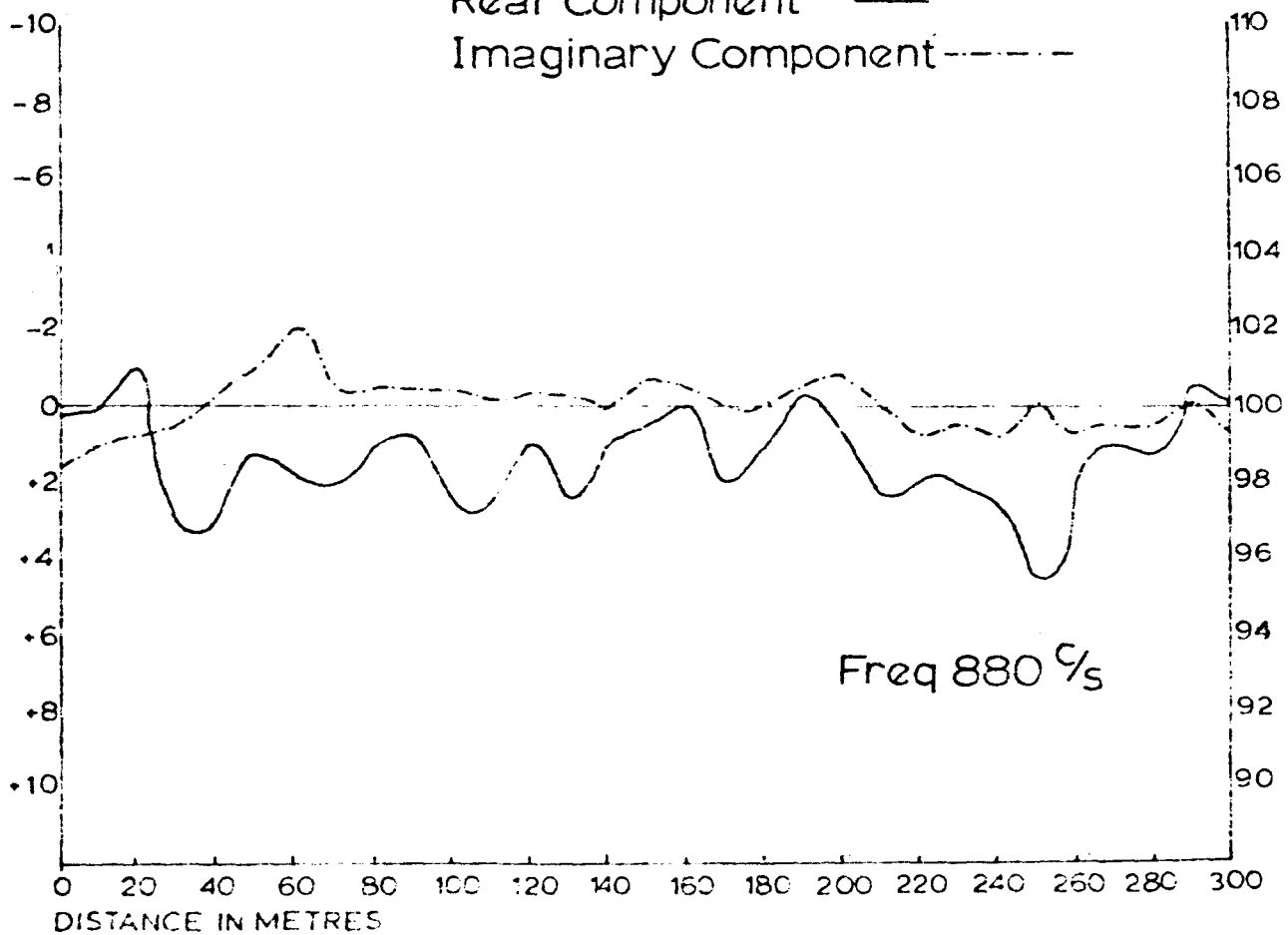

FIG. 11 E.M. Traverse 3
 Coil Separation 60M
 Station Interval 10M
 Real Component —
 Imaginary Component - - - -



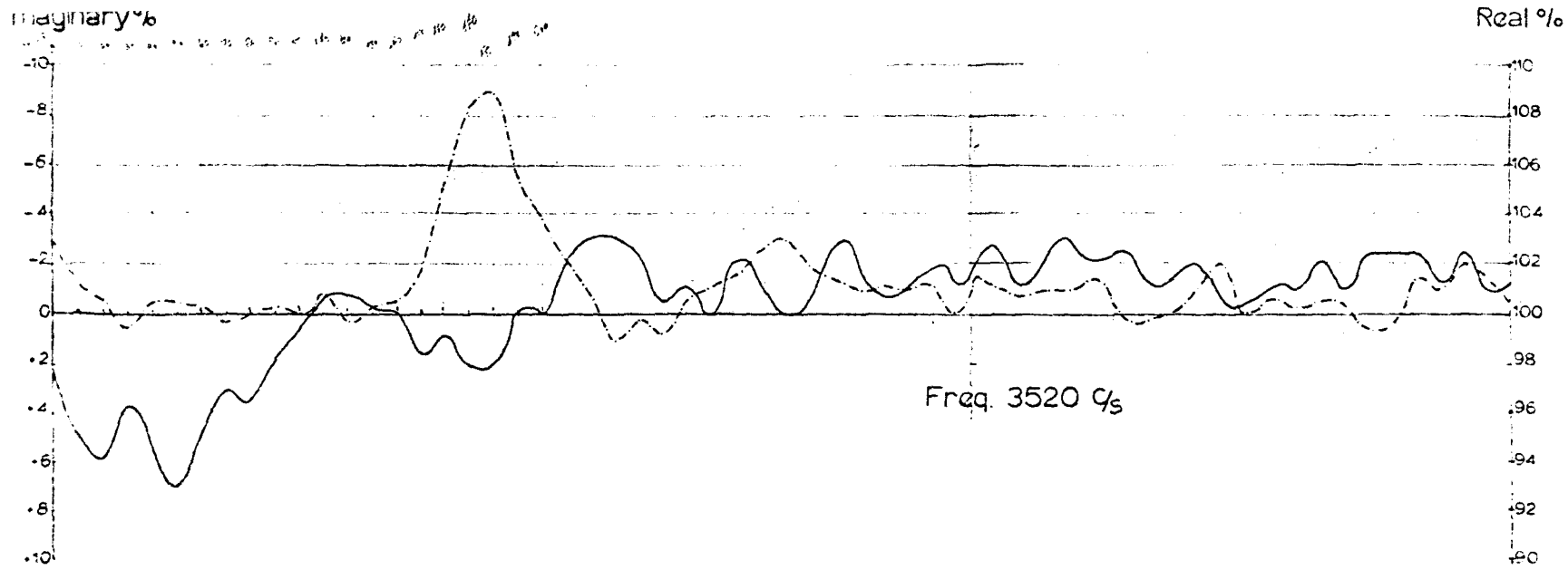
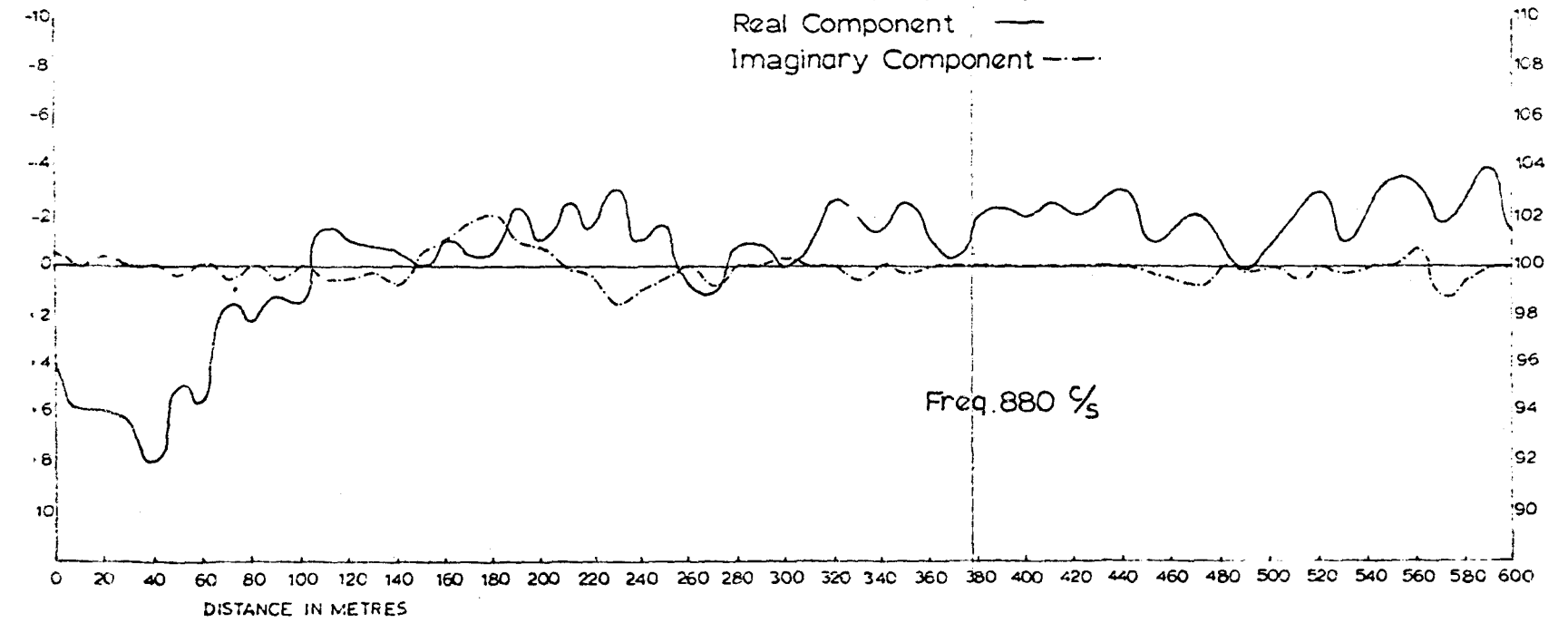
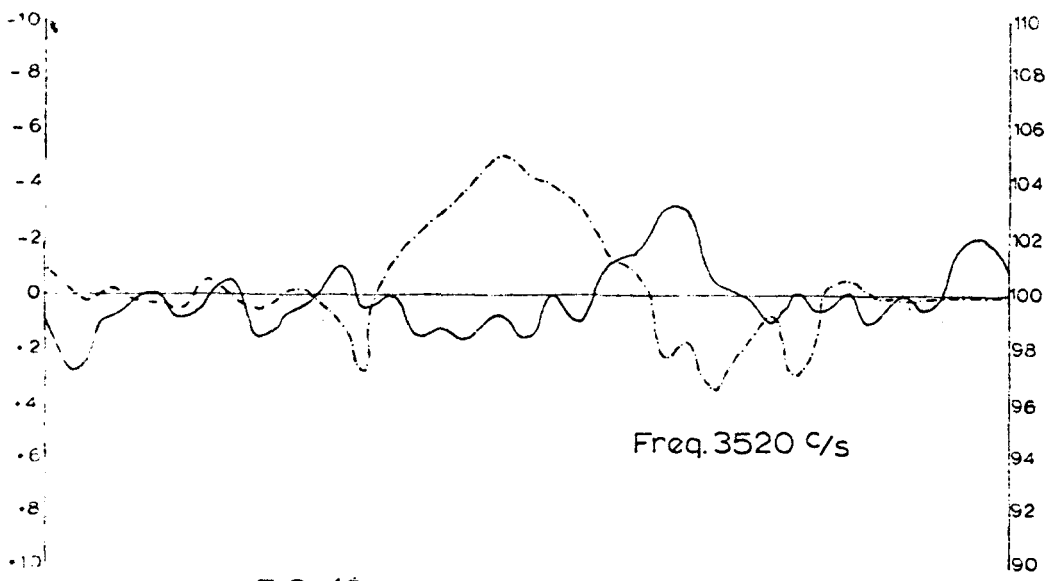

FIG. 12 E.M. Traverse 4
 Coil Separation 60M.
 Station Interval 10M.
 Real Component —
 Imaginary Component - - -



Imaginary %

Real %



Freq. 3520 c/s

FIG. 13
 E.M. Traverse 5
 Coil Separation 60M.
 Station Interval 10M.
 Real Component. —
 Imaginary Component. - - -

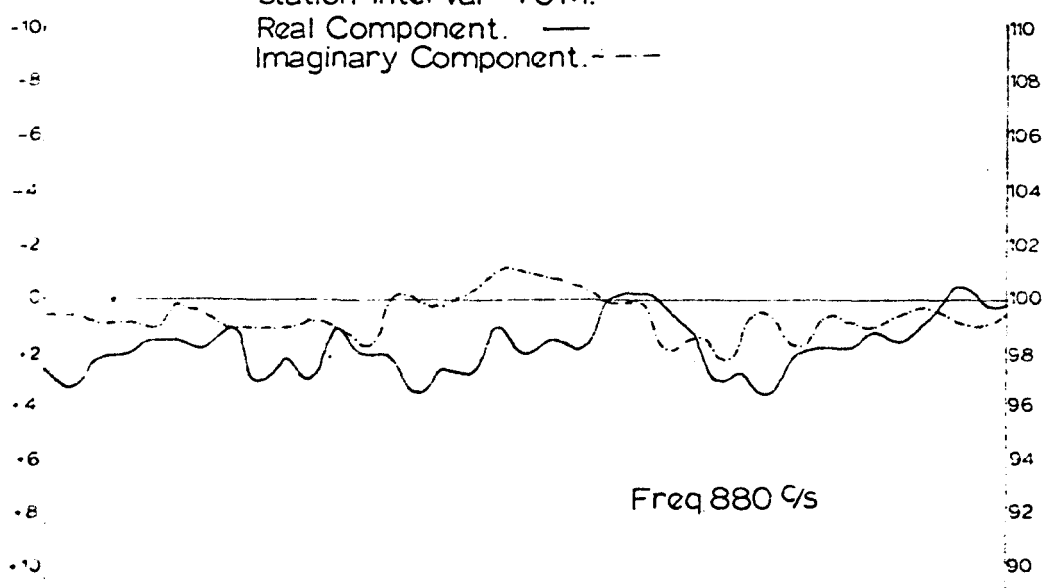

Freq 880 c/s

DISTANCE IN METRES

Imaginary %

Real %

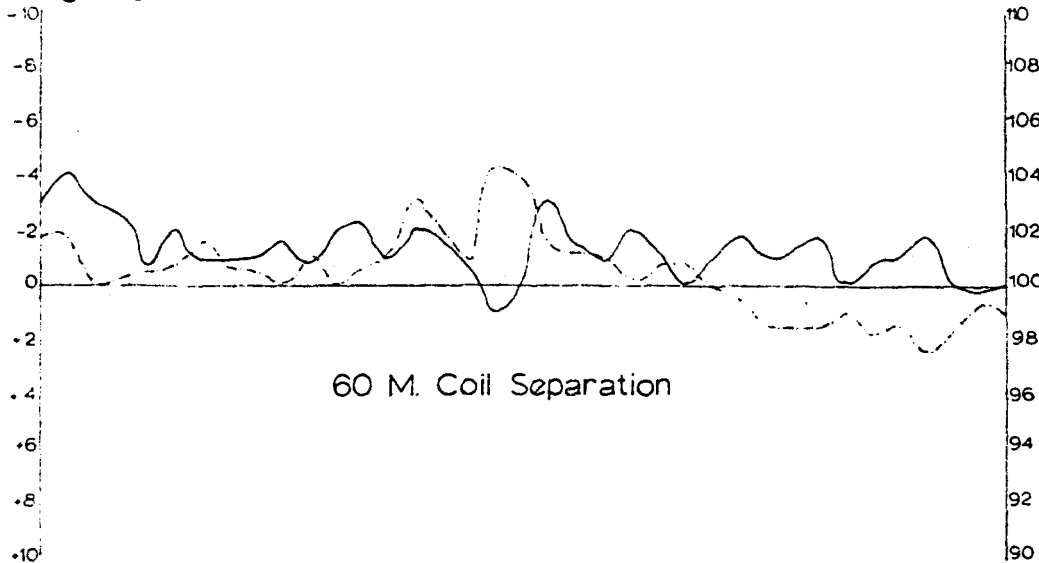
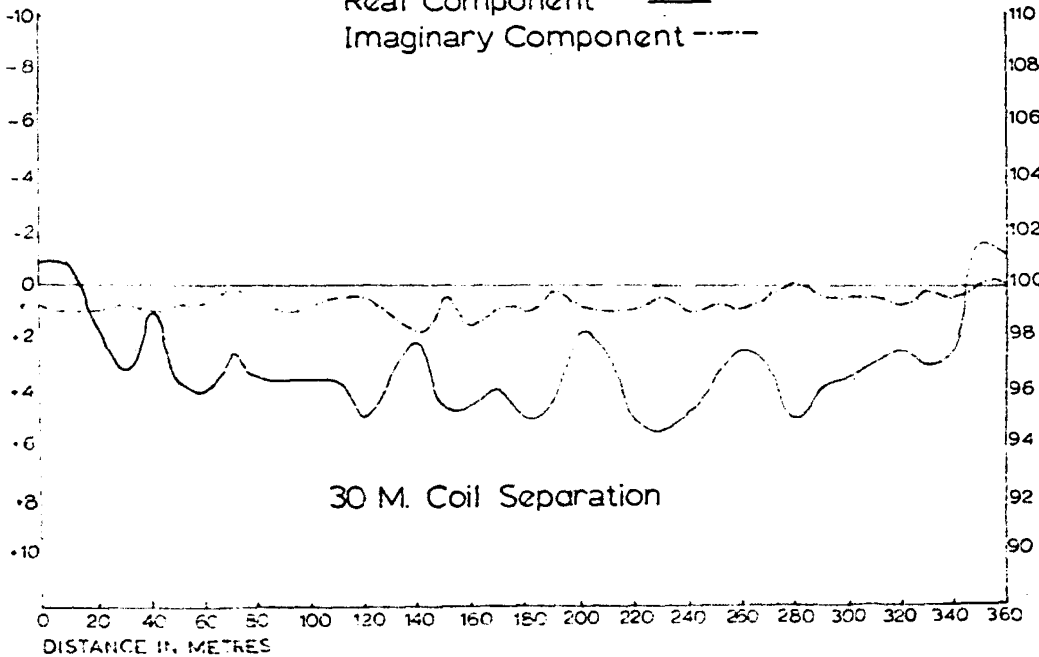
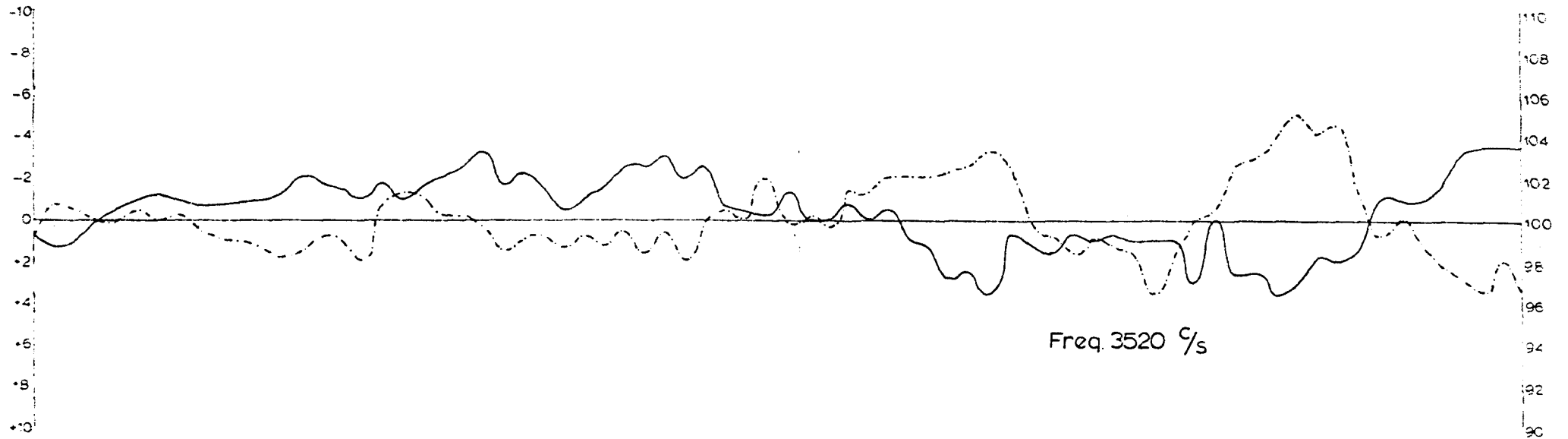

FIG. 14 E.M. Traverse 6
Station Interval 10 M.
Frequency 3520 C/s
Real Component —
Imaginary Component - - -





Freq. 3520 c/s

FIG 15
E.M. Traverse 7
Coil Separation 60M.
Station Interval 10M.
Real Component —
Imaginary Component - - -

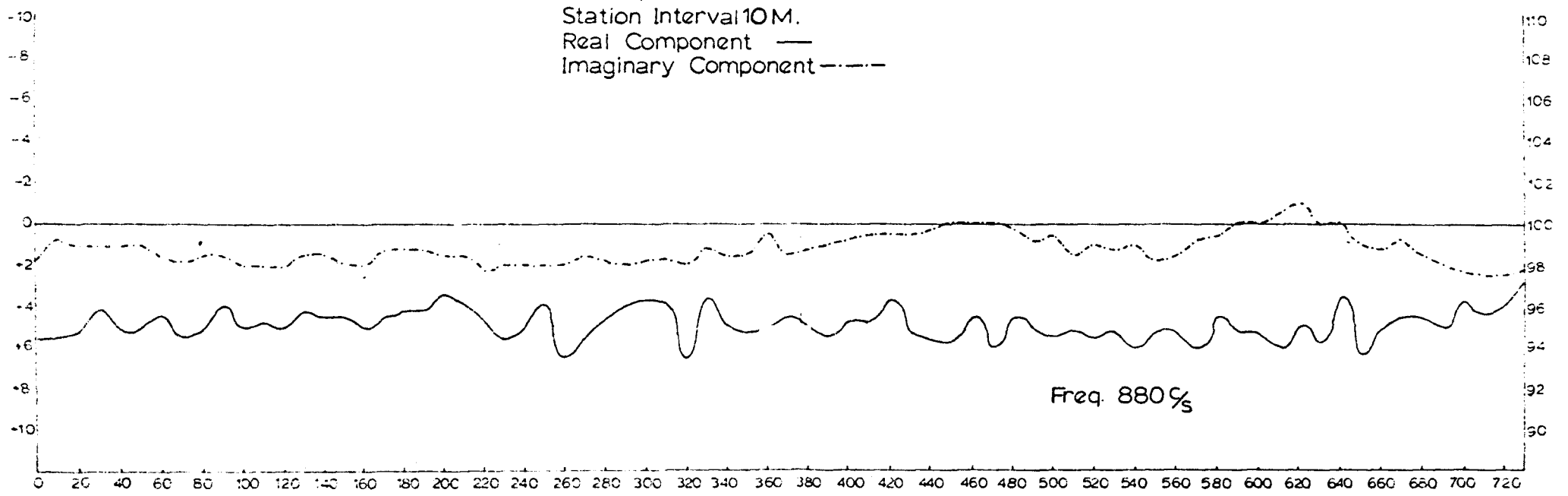

Freq. 880 c/s

DISTANCE IN METRES

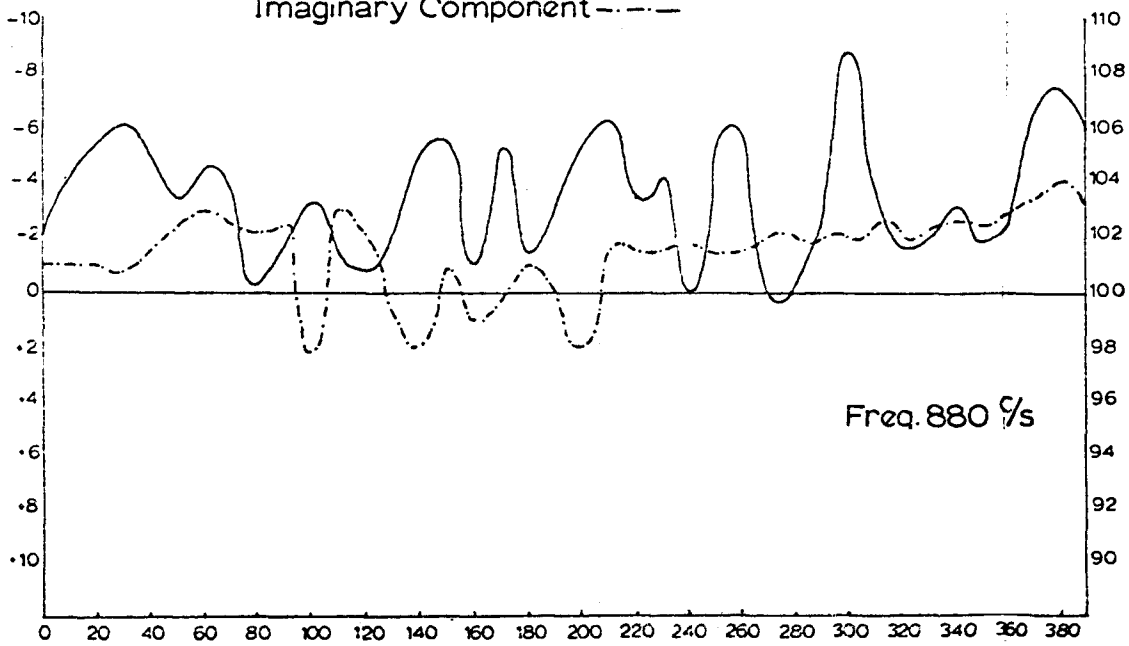
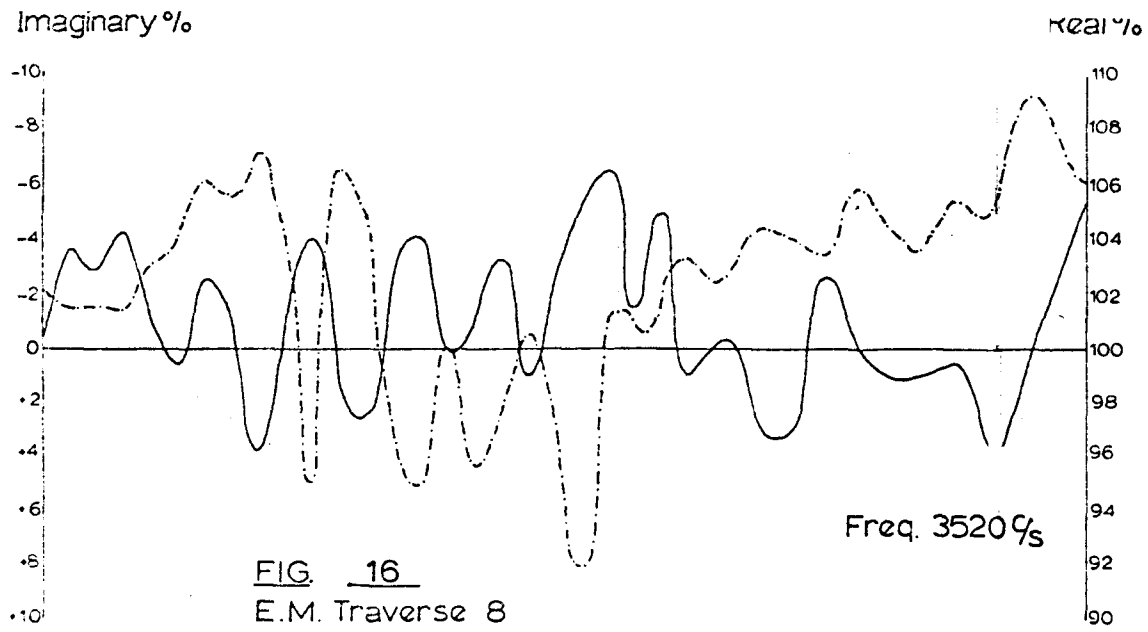

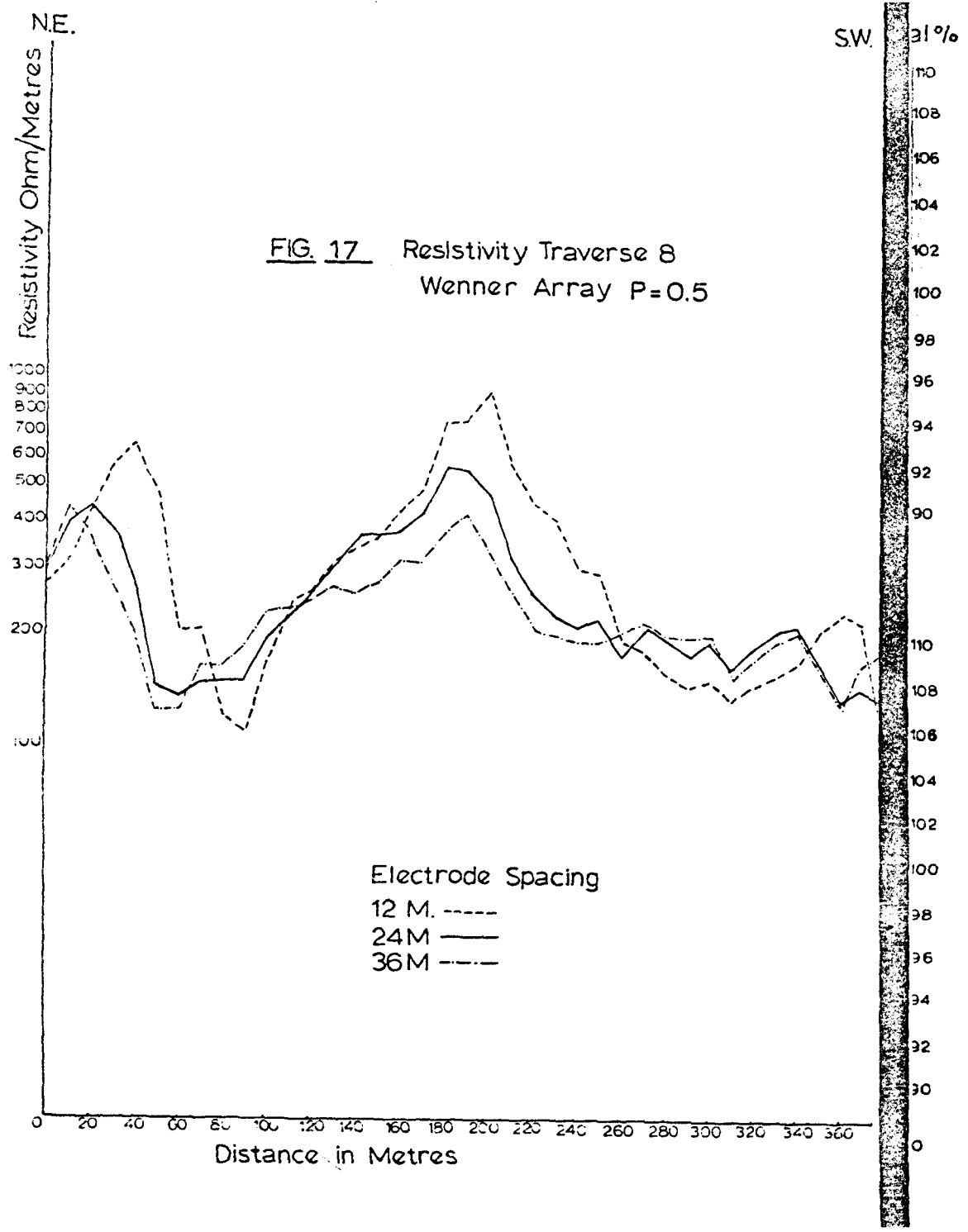

SW.
R‰
Q‰



FIG. 18
V.L.F. EM. Traverse 3
Transmitter NAA
Station Interval 10M
Real Component —
Quadrature Component - - -
Direction of Readings →

Transmitter NAA

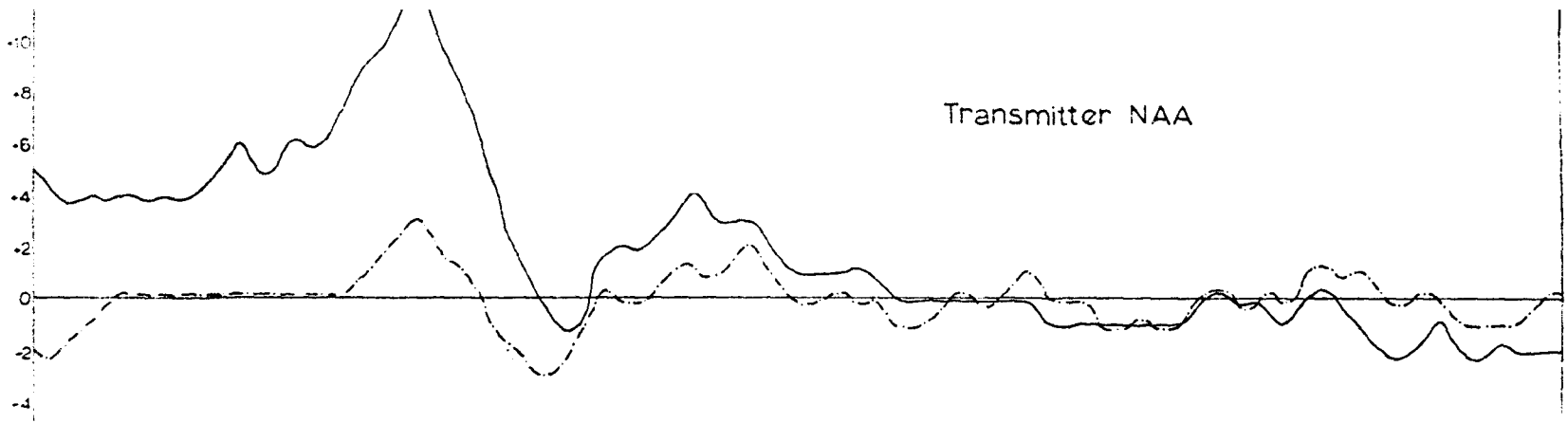
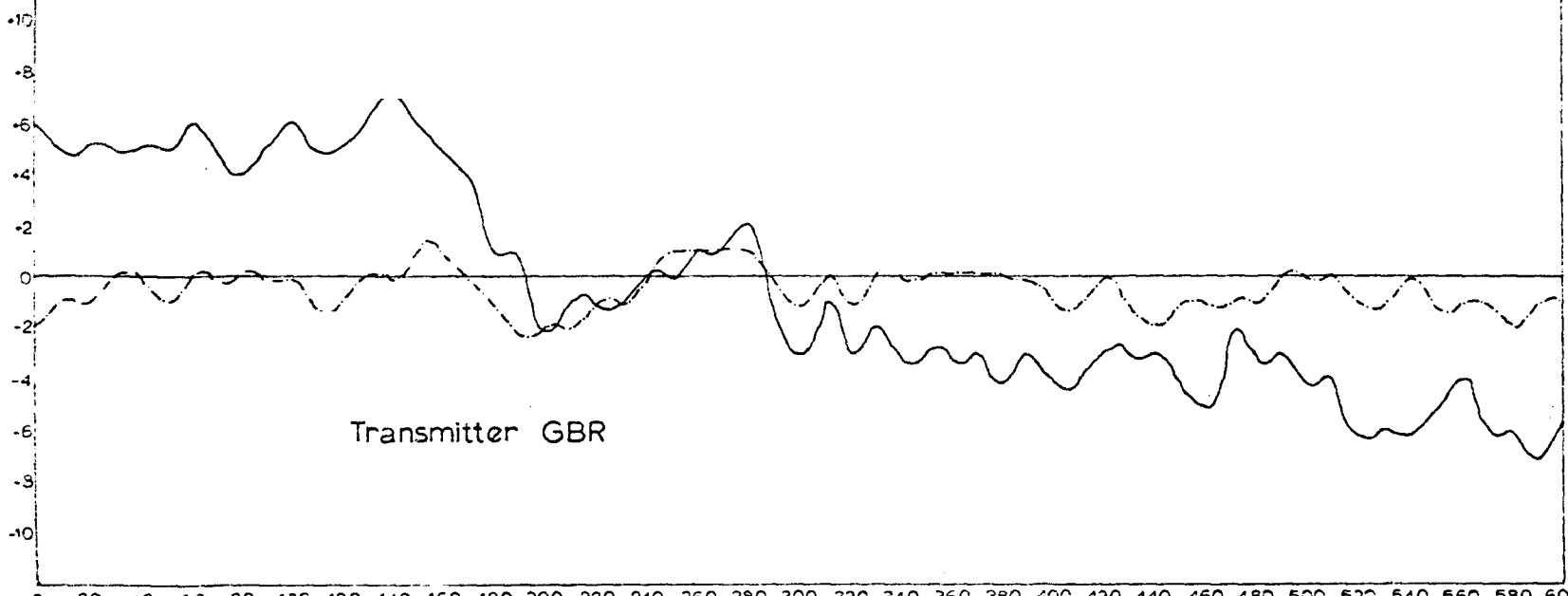

FIG. 19
VLF EM. Traverse 4
Station Interval 10M
Real Component —
Quadrature Component - - -
Direction of Readings →

Transmitter GBR



DISTANCE IN METRES

D.S. Survey, Middleton Common.

July, 1972

Report on work carried out for Swiss Aluminium Mining (U.K.) Ltd.
by Mr. L. I. Gentry and Dr. J. O. Myers.

Head of Department - Professor P. A. Young.

Summary.

After an introduction briefly outlining the possibility of Westernhope Old Vein continuing in a south-easterly direction as a mineralised fault, a section is included describing the geophysical methods used in the present survey.

In the next part of the report results are presented from geophysical traverses over a known vein in the area, in order to determine the kind of anomalies likely to be found over such features.

A large section is devoted to the results obtained from a number of traverses over the possible line of extension of Westernhope Old Vein. The V.L.F. E.M. method was found to give comparable results to the normal E.M. method, and was much quicker to carry out.

From the results the anomalies found were plotted on a map of the area and some indication of a continuous linear feature is given. Recommendations are made as to the two most suitable sites for further investigational work.

The report concludes with a summary of further geophysical work contemplated in the area, both as an extension to the present survey, and from a research point of view.

An appendix describes the basic principles of the three geophysical methods used in the survey. Namely V.L.F., E.M., moving-source-receiver E.M. and electrical resistivity.

Report on Results of Geophysical Survey to Locate Position of
Possible Extension of Westernhope Old Vein.

Introduction

Westernhope Old Vein was formerly worked for lead ore in the 19th Century. Fluorspar has since been worked from the dumps in the vicinity of the mine.

The 1" Geological Map (Sheet No. 25) shows Westernhope Old Vein continuing in a South-Easterly direction as a fault downthrown to the North-West. A fault with a slightly different strike, downthrown to the South-East continues down to the junction of Firegill North Vein and Little Egglehope Vein. Six inch to the scale geological maps in the possession of Samak Ltd. show a slightly different pattern of faults.

It is thought that Westernhope Old Vein may continue in a South-Easterly direction as a mineralised fault and link up with Firegill North Vein and Little Egglehope Vein. The present survey was initiated to test this possibility and locate likely sites for chemical work, trenching, drilling, etc.

The basic E.M. survey which was requested has been supplemented by a limited amount of electrical resistivity work and some V.L.F. experiments as a part of the Mining and Mineral Sciences Department research programme. A description of this part of the work is also included in this report.

Methods Used.

Moving source-receiver EM has been used on all the traverses so far. The resistivity method has been used on only one traverse apart from traverses over a known vein, Little Egglehope Vein. Towards the end of the field period VLF EM was tried over Little Egglehope Vein and two of the traverses for the survey. Notes on the principles of these three different methods are appended in separate leaflets.

In searching for fluorspar veins, the theory of their location assumes that the veins themselves are more fissured than the country rock. This fissuring allows a greater water content and hence an increase in the conductivity of the vein compared to the country rock. Galena, a common associate of fluorspar mineralisation, probably plays a significant part in making the vein a conducting body, but fluorspar being a non-conductor cannot be detected directly. Because of this it must be stressed that at this point in the research work concerned with the search for fluorspar by geophysical means, little is known of the differences between anomalies over non-mineralised faults and those over veins. As faults are fairly often mineralised in the Northern Pennines location of such at the surface may provide suitable targets for drilling.

Results over Little Egglestone Vein

Traverses over a known vein, Little Egglestone Vein, have been made in order to discover the kind of anomalies to be expected when searching for new veins. The location of the traverse is shown in Fig. 3. The country rock in the vicinity is sandstone belonging to the lower part of the Upper Carboniferous System.

E.M. Results.

E.M. Traverses have been done using two frequencies at coil separations of 30 metres and 60 metres. The results are shown as real and imaginary component values for one frequency plotted against traverse distance. The imaginary scale is on the left, the real scale being on the right.

The traverse results for a coil separation of 60 metres are shown in Fig. 4. Using 3520 c/s the imaginary component values show varying negative values up to -4.5 until a positive peak is reached at 270 metres, followed by a good negative anomaly at 330 metres. A second positive peak, smaller than the one to the North, is seen at 400 metres. The larger positive peak being to the North suggests that the vein dips in this direction, but other evidence discussed later contradicts this. The value of -4.5 at 190 metres can only be termed a doubtful anomaly as it has only one positive peak associated with it. The real component values for the traverse show fairly wide variations, mainly negative, with a negative peak to the South. This peak may be due to an underlying shale layer.

The width of the anomaly associated with the vein is approximately 90 metres, indicating a broad zone of conductivity of 30 metres. The vein can be termed a poor conductor as the ratio of real to imaginary components at the anomaly is less than one. This traverse located the vein about 20 metres to the South of its position shown on an old mine plan of the area.

Using 3520 c/s a good anomaly is seen for the imaginary component at 320 metres with two positive peaks of equal size on each side. Elsewhere the imaginary component shows low negative values that are fairly stable. The real component shows small varying values, mainly negative, with nothing of significance over the vein. As compared to the curves for 3520 c/s the anomaly is wider and displaced slightly to the North. The anomaly size for the imaginary component is larger for the higher frequency, this being in accord with electromagnetic induction theory.

Using a coil separation of 30 metres, curves for the traverse are shown in Fig. 5. Using 3520 c/s the imaginary component shows a small anomaly of -2% at 310 metres, with a positive peak on either side. Apart from the anomaly and its associated positive peaks, the imaginary component generally has a small negative value until 365 metres when it becomes positive. This indicates some small change in the lithology of the surface rocks. The real component shows nothing of significance.

Using 880 c/s the imaginary component shows small negative values with a peak at -0.5% over the vein. The change to slightly positive values occurs at a similar position to that when using 3520 c/s. The real component shows fairly wide variations with nothing of significance.

The anomaly centre using a coil separation of 30 metres is at 310 metres for both 3520 and 880 c/s, this is in good agreement with the known position of the vein. With a small coil separation the part of the vein actually "sampled" is nearer the surface than with a larger coil separation. As the anomaly centre is positioned further to the South for the 60 metre coil separation this indicates that the vein in fact dips to the South. The large positive peak to the North of the anomaly when using 3520 c/s and 60 metre coil separation must be caused by some geological feature to the North of the vein.

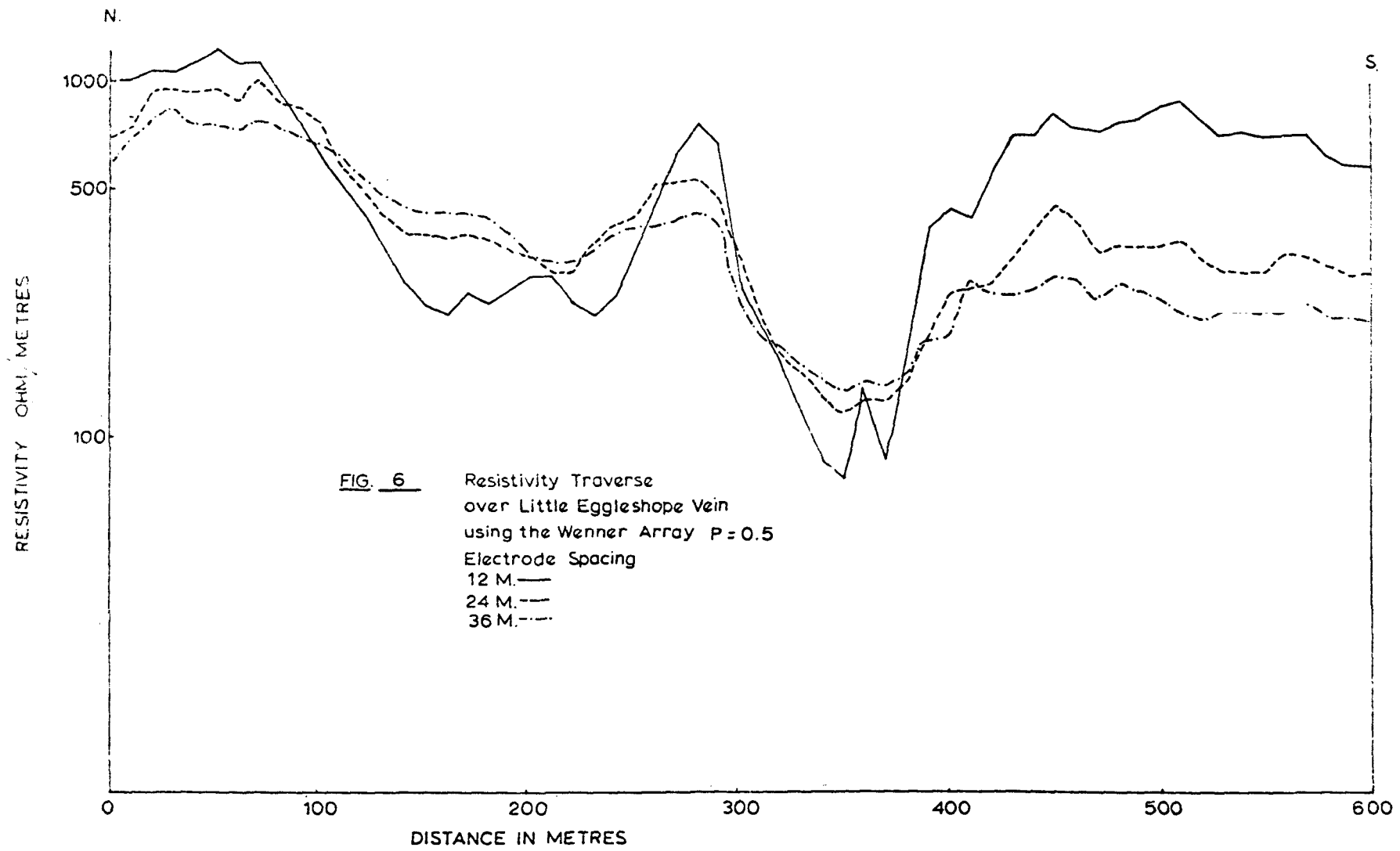

FIG. 6 Resistivity Traverse
over Little Eggeshope Vein
using the Wenner Array $P=0.5$
Electrode Spacing
12 M.—
24 M.—
36 M.—

In considering these results it is seen that the largest and most easily recognisable anomaly for the imaginary component is obtained when using 3520 c/s with a coil separation of 60 metres. The real component values do not appear to contribute significantly to the results. With a coil separation of 30 metres the anomalies are much smaller and the near-surface geological effects are shown up much more.

Resistivity Results. See Fig.6

The first part of the traverse shows resistivity values up to 1200 ohm-metres, with the smaller electrode spacing giving the highest readings. Between 100 and 270 metres a broad low resistivity region is encountered, the lowest readings being obtained with the smallest electrode spacing. High resistivity values at 280 metres are followed by a low resistivity area centred on 350 metres which is thought to indicate the vein, in a position, however, slightly further South than both the V.L.F. D.M. and E.M. methods indicate it. From this anomaly the resistivity values sharply increase again and then remain fairly steady for the rest of the traverse.

The curves obtained show a distinct pattern with regard to resistivity and spacing. For the high resistivity regions, the highest resistivity values are obtained for the smallest electrode spacing, with decreasing values for increased spacing. The opposite effect is seen to be the case for the low resistivity areas. One possible cause for this may be the effect of overburden.

V.L.F. E.M. Results. See Fig.7.

Real and quadrature component values are both positive for the first part of the traverse. For the real component a cross-over is seen at 200 metres. This correlates with a low resistivity region, and also with a vague anomaly for the E.M. traverse.

At 340 metres a good anomaly is encountered with strong peaks

on both sides. The quadrature component polarity follows the real component and indicates that the vein is a poor conductor. The relative sizes of the peaks suggest that the vein dips to the North. This is in agreement with the E.M. results using 3520 c/s and a 60 metre coil separation, but at variance with the evidence from the other E.M. results.

The rest of the traverse shows the real component values becoming increasingly negative, while the quadrature component is slightly positive. This may be due to an underlying shale layer. Similar effects were noted for the E.M. traverse.

NAA, the station used for this V.L.F. E.M. traverse, is almost in line with the strike of the vein and therefore gave a good anomaly. Readings were also taken using GBR, but, as would be expected, the results showed nothing of significance as this transmitter lies in an unfavourable direction to the strike of the vein.

Results over Possible Line of Old Westernhope Vein.

The positions of the traverses completed are shown on a map of the area depicted in Fig.8.

Initially Traverses 1, 2, 4, 7 and 8 were located in an attempt to find recognisable anomalies that might indicate the vein. Traverses 3, 5 and 6 were then located according to results obtained initially. E.M. measurements have been taken over all the traverses, P.L.P. E.M. being tried on traverses 3 and 4. Resistivity measurements were taken over traverse 8.

The country rocks in the vicinity of traverses 1 to 7 are sandstones and grits belonging to the lower part of the Upper Carboniferous Series. Traverse 8 is located over alternating sandstones and shales slightly lower in the succession.

E.M. Results.

Traverse 1. See Fig.9.

The imaginary component shows small, slightly variable negative values with a broad anomalous zone peaking at 380 and 430 metres. Small positive peaks occur on each side. The real component generally shows positive fluctuations. Using 880 c/s the imaginary component confirms the broad anomalous zone with another one further to the North-East. The real component again shows fluctuations of a positive order.

The anomalies obtained on this traverse are of doubtful type as they are not of the right order of width to indicate narrow vertical veins nor do they show a steady rise and fall to some peak value.

Traverse 2. See Fig.10.

This traverse is located 35 metres from an old air shaft and the imaginary component values for 3520 c/s show that it starts to one side of a possible anomaly. This may be caused by metal bars etc. in the shaft itself.

The imaginary component at 3520 c/s shows two anomalies located at 80 and 130 metres and these are accompanied by large negative values for the real component. The ratio of real to imaginary components for the first anomaly (at 80 m.) is slightly less than one, and for the more North-Easterly anomaly it is slightly greater than one. These values indicate structures having a higher conductivity than that found over Little Eggeshope Vein. For 880 c/s the imaginary component values show anomalies at 80 and 200 metres. At these points there are less well-defined real component anomalies.

Traverse 3. See Fig.11.

For 3520 c/s the imaginary component values show no definite anomalies but negative peaks occur at 60 and 200 metres. These negative peaks for the imaginary component are confirmed by similar ones of smaller magnitude when using 880 c/s. For both 3520 and 880 c/s the real component values show nothing of significance.

Traverse 4. See Fig.12.

On this traverse the imaginary component values for 3520 c/s show a very good anomaly at 180 metres and a smaller anomaly at 200 metres. The positive peaks on each side of the first anomaly are very small but indicate a slight dip to the North-East of the feature causing the anomaly. The positions of these two anomalies are confirmed by peaks of smaller magnitude in the same positions when using 880 c/s.

For the real components at 3520 c/s a negative value is obtained for approximately the first 100 metres of the traverse and then a positive peak is discernible corresponding to a similar one for the imaginary component. This is followed by a

regue negative anomaly, a positive peak and then slightly varying positive values for the rest of the traverse.

For the real component at 380 c/s negative values are again seen for the first 100 metres followed by slightly varying positive values for the rest of the traverse, apart from one negative point at 270 metres.

Traverse 5. See Fig.13.

Imaginary component values for 3520 c/s show a good anomaly at 170 metres with positive peaks on either side of it. The size of these peaks indicates a dip to the North-East of the feature causing the anomaly. Real component values show positive peaks on either side of the imaginary component anomaly with a slight negative region over the anomaly itself. The anomaly is confirmed by imaginary component values at 880 c/s but the real component values show nothing of interest.

Traverse 6. See Fig.14.

On this traverse, readings were taken at a frequency of 3520 c/s for two coil spacings, namely 60m and 30m. Any anomaly found using the larger coil spacing would decrease in size when using the small coil spacing if it were caused by a feature at depth, whereas if the anomaly was caused by overburden effects, theoretically it should increase in size with a smaller coil spacing.

An indeterminate imaginary component anomaly is found at 170 metres when using a 60 metre coil spacing. No positive peaks are present on either side of the anomaly. Using the smaller coil spacing the anomaly is seen to disappear completely which suggests that it is caused by some deep-seated feature.

For the 60 metre coil spacing the real component values are positive except for a negative region over the imaginary component anomaly. The real component values for 30m are negative except for readings at each end of the traverse.

Traverse 7. See Fig.15.

For 3520 c/s imaginary component values show two anomalies at 470 and 620 metres, the latter being the larger of the two. Both anomalies are associated with regions of negative real component values, the ratio real to imaginary component tending to one, suggesting that the features causing the anomalies have a medium conductivity (greater than Little Egglehope Vein for example). These anomalies are confirmed by regions of zero and slightly negative imaginary component values for 880 c/s. The real component values for this frequency are negative for the whole of the traverse and show nothing of significance.

Traverse 8. See Fig.16.

This traverse was sited over an area which had distinct disadvantages for geophysical methods i.e. fairly steep topography and alternating sandstones and shales. The traverse direction was approximately perpendicular to the strike of the geology.

For 3520 c/s imaginary component values are fairly steadily negative, until an area from 90 to 210 metres over which they fluctuate widely, becoming steady and negative for the rest of the traverse. This pattern is repeated for 880 c/s with the situations being in step with each other for both frequencies.

The real component values for both frequencies show wide fluctuations for the whole of the traverse although some kind of trend is discernible. In the region 90 to 210 metres a positive trend for the imaginary component is accompanied by a positive trend for the real component, the same correlation occurring for positive values. This pattern is easier to see for the readings 3520 c/s than those at 880 c/s.

From the resistivity results (see below) the geological sequence is seen to be sandstone/shale/sandstone/shale along the

reverse. The zone of widely varying imaginary component values probably corresponds with a sandstone region, the fluctuations probably being caused by changes in sandstone and/or overburden thickness. The areas of steady negative values for the imaginary component must be caused by the shale layers.

From these initial results it seems that it would be difficult to pick out an anomaly due to a vein in an area of frequently alternating sandstones and shales. The supposed vein or fault is thought to pass across this traverse but nothing indicating such a feature can be seen from the results.

Resistivity Results for Traverse 8. See Fig. 17.

The resistivity curves for all three spacings clearly shows up the known geological sequence. A similar pattern of electrodes spacing versus resistivity to that seen from the traverse results over Little Eggeshope Vein is found, that is the smallest electrode spacing shows the highest resistivity values over the resistivity highs and vice versa for the resistivity lows.

It can be seen from the curves that the high resistivity values obtained over the sandstones occur at different positions for different electrode spacings. This must be because the traverse line is not exactly perpendicular to the strike of the geology. From a consideration of the EM results for this traverse, the resistivity low for all three electrode spacings at approximately 80 metres can be attributed to the shale layer only and there is little possibility that it is due to a vein. Both the resistivity and EM methods are at a considerable disadvantage when outcropping shale layers are present but it is considered here that the EM method may have a distinct factor in its favour over the resistivity method in distinguishing between a horizontal shale layer and a vertical vein. If the detailed geology of a survey

was unknown a resistivity anomaly such as that contred at
in Fig. 17 could be mistaken for a vein but the results
show that no vertical conducting bodies are present.

7.1.5. E.M. Results.

Traverse 3. See Fig.18.

The quadrature component values show a cross-over at 46 metres. This may correlate with an indeterminate E.M. anomaly at 60 metres. The real component values show a high peak at 40 metres and a descent to a low peak at 86 metres. The midpoint of these two peaks is 63 metres, agreeing with the weak E.M. anomaly. Some local geological feature is causing strong positive real values to be present for most of the traverse.

Traverse 4. See Fig.19.

Using GBR the real component values show cross-overs at 194 and 288 metres. These can be correlated with E.M. anomalies at 180 and 300 metres. For NAA the only definite cross-over seen is at 200 metres, although the anomaly as a whole stands out better than the one given when using GBR. This is most probably because the geological structure causing the first anomaly has a more favourable strike direction for NAA than GBR, whereas the opposite is the case for the second anomaly seen only on the GBR curves.

The quadrature values given for NAA show the same polarity as the real values for the anomaly although the cross-over is some 20 metres further to the South-West. Similarly for GBR the real and quadrature values have the same polarity over the anomalies. This indicates that the geological structures causing the anomalies have different conductivity.

When considering the curve for the real component values using GBR an interesting effect can be seen. To the South-West of the anomalies the values are positive, while to the North-East they are negative. This effect can be seen to a lesser extent when using NAA. It is most probably caused by faulting within the geological structures causing the anomalies, so that different rock types occur on either side of the fault.

Recommendations

The E.M. anomalies are plotted on the traverse lines as shown in Fig.8. They are considered in two groups; good anomalies and doubtful anomalies. The good anomalies are thought to be of the shape, size, etc., indicative of a vertical conducting feature having a higher conductivity than the surrounding country rock, whereas the doubtful anomalies may or may not be caused by such features.

Some suggestion of a continuous linear feature is given by the anomalies on traverses 3 (60 metres), 4 (180 metres), 5 (170 metres), 6 (170 metres) and 7 (620 metres). The anomalies on traverse 2 may be connected with the above.

From a consideration of the size and shape of the anomalies present, the most suitable sites for further investigation (e.g. by geochemical methods) would be those on traverses 4 (180 metres) and 5 (170 metres).

Further Geophysical Work Contemplated

From a research point of view resistivity traverses are envisaged over those lines where good E.M. anomalies have been found. Also further work must be done to distinguish between the effects due to fault zones and mineral veins. At this stage it seems that E.M. and V.L.F. E.M. may have more to offer in this respect than the resistivity method.

Although the V.L.F. E.M. equipment was only available for a very short time enough results were obtained to show that it was capable of detecting a known vein and also gave anomalies where E.M. anomalies had been recorded. Effects probably due to differing sandstone types were noticed and if the equipment becomes available again research into this aspect would be undertaken. The V.L.F. E.M. method is much quicker to carry out than either of the other methods used on the present survey and if interpretation techniques for the area can be developed it could prove very useful.

If back-up geochemical work or trenching/drilling proves the anomalies to be due to a vein, further geophysical work could be undertaken east and west of traverses 3-7 to delineate its strike direction, although the outcropping sandstones and shales in the vicinity of Great Egglehope Beck may prove a limiting factor.

1:1000

40 3250

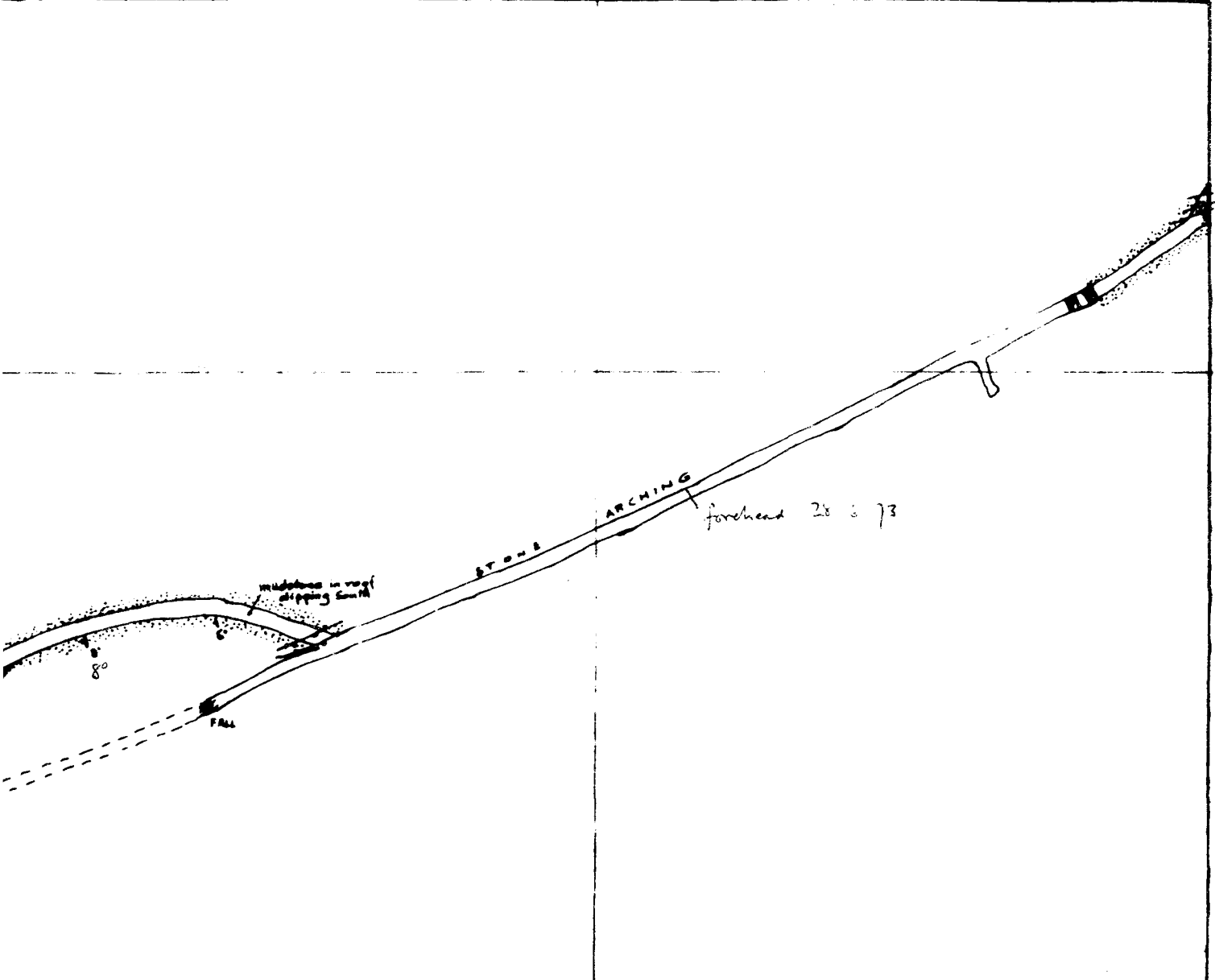

For and on behalf of:-
Swiss Aluminium Mining (UK) Ltd.

H. M. Hurst
Managing Director

03. 07. COORDINATES

6.11.14.76.

A.E. 52
CORNISH HUSH MINE

14.4.80.



1:1000

3220

3230

3240

3250

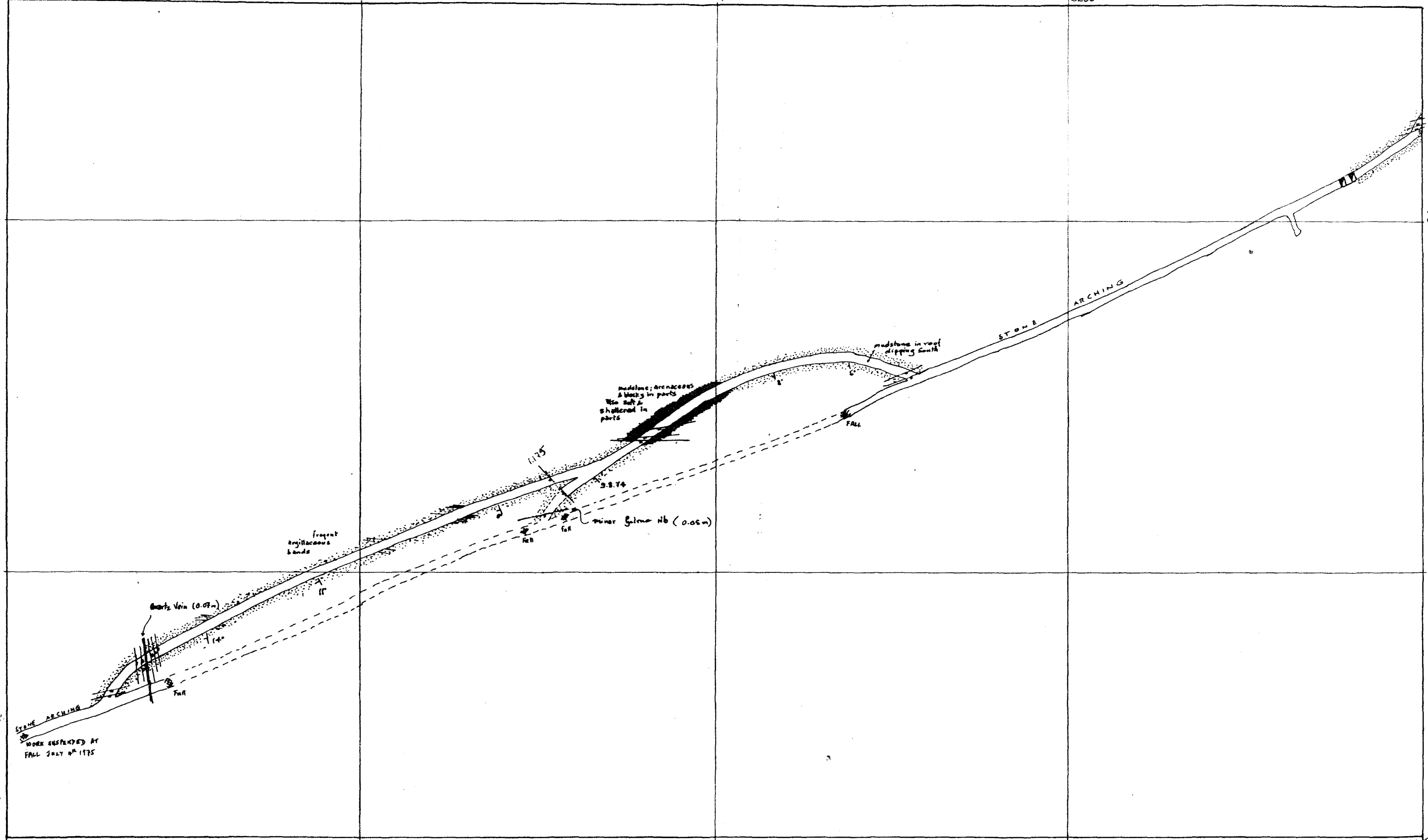

O.S. GRID CO-ORDINATE

G.H. 14.4.76.

CORNISH HUSH MINE. (S.A.M.U.K.)

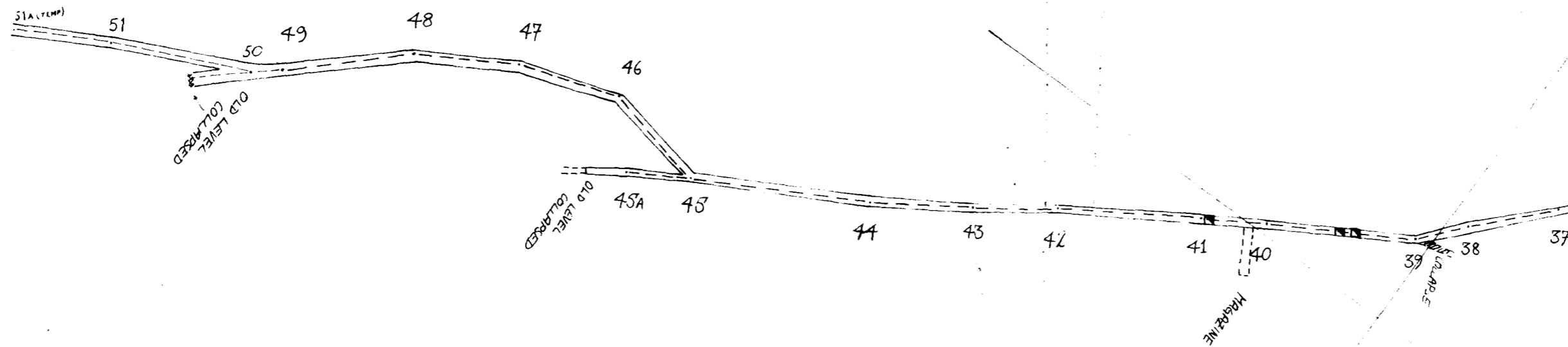

Scale; 1:1000 m. (9)

SURVEYED 18, 20 SEPT 1974

DRAWN BY [Signature] 22 Sept 1974

Updated 11.11.74. 2. Hughes. Sta 49 to Sta

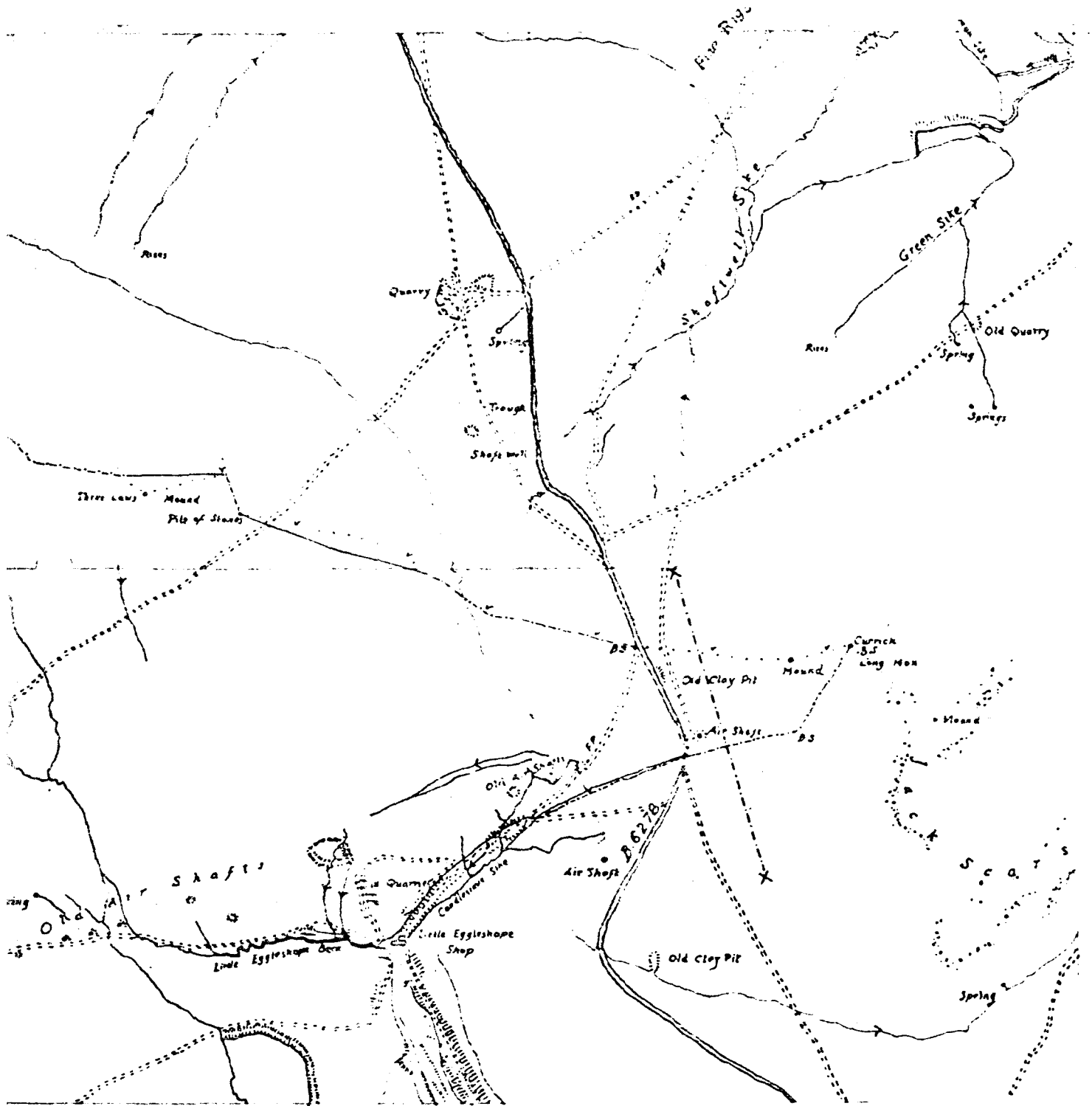

X--- Traverse position over Little Eggeshope Vein

Scale 6 ins = 1 Mile or 1:10,560

FIG. 3

Little Eggeshope Area

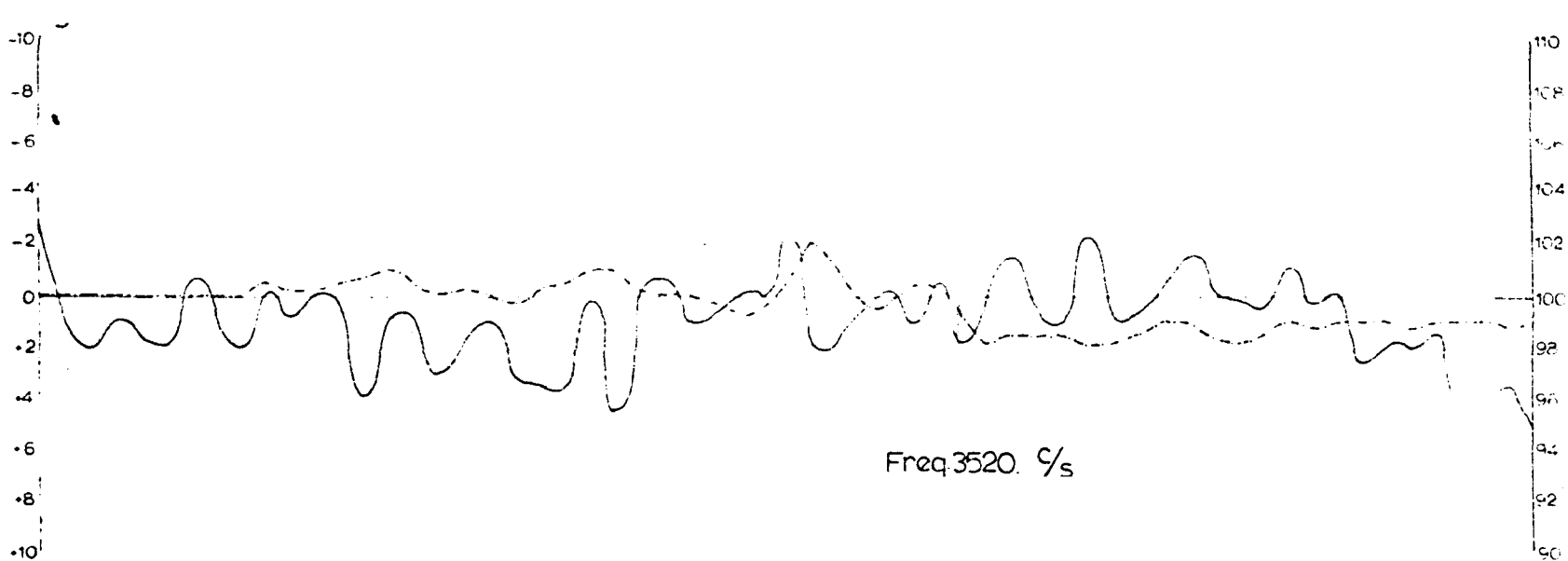

Freq. 3520 1/s

FIG. 5

E.M. Traverse over The Little Eggeshope Vein

Coil Separation 30 M.

Station Interval 10 M.

Real Component —

Imaginary Component - - - -

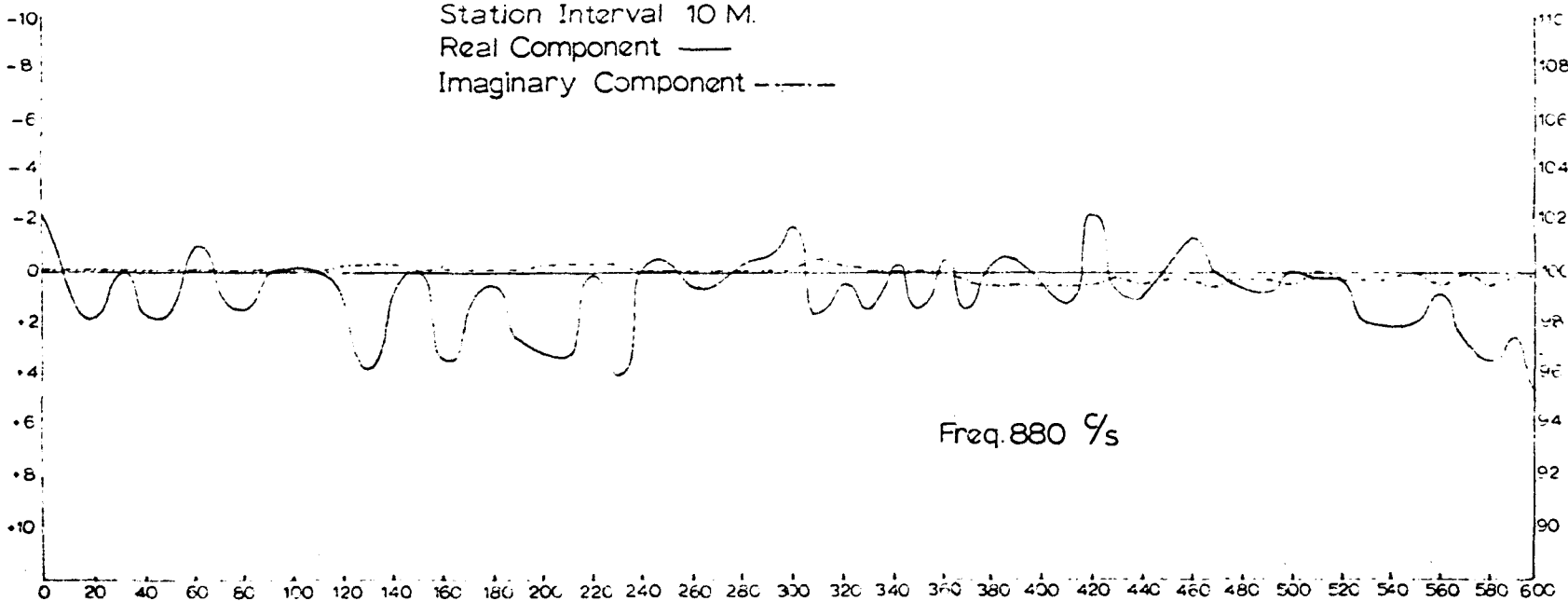

Freq. 880 1/s

DISTANCE IN METRES

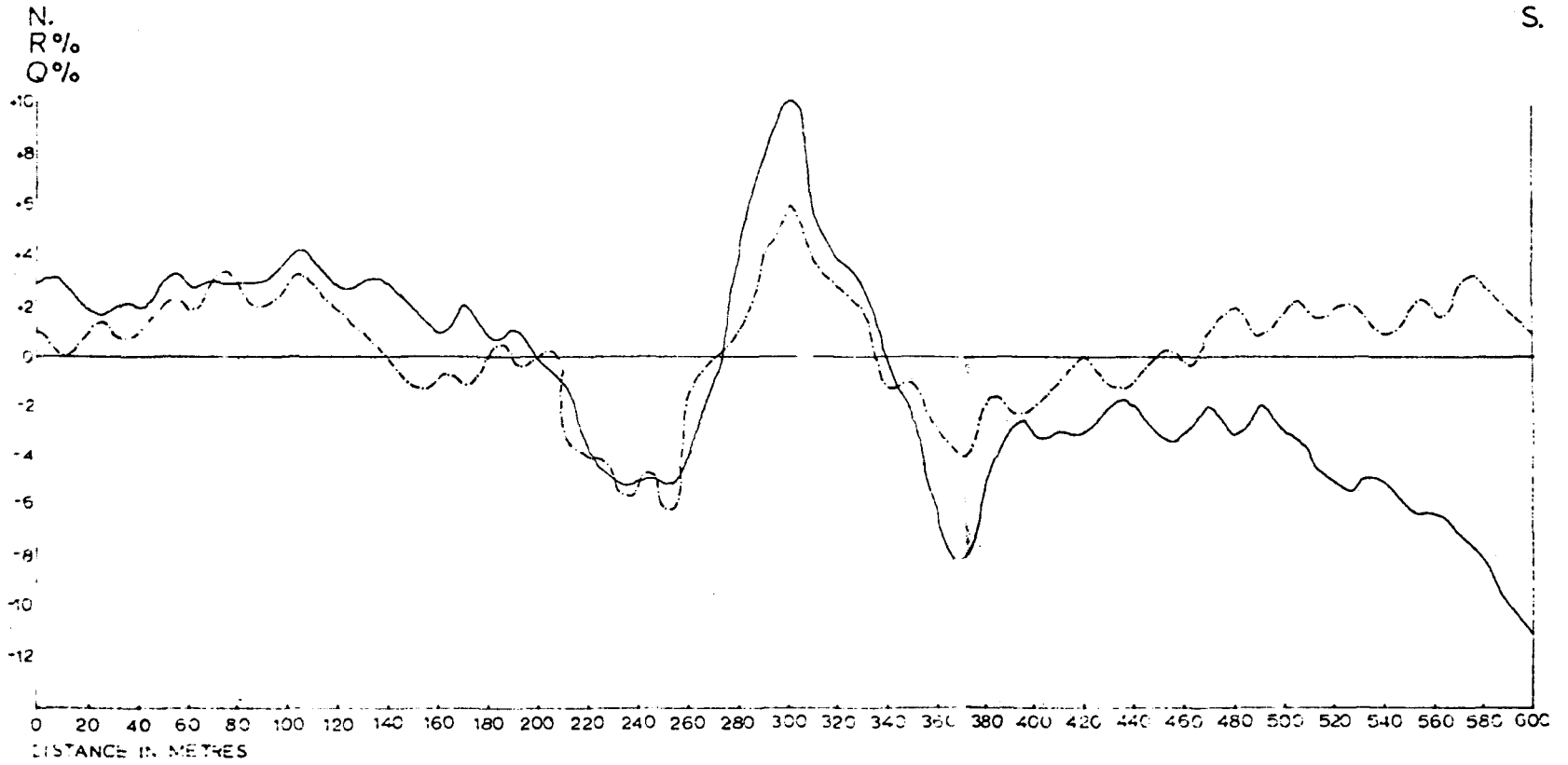

FIG. 7
VLF EM Traverse over Little Eggeshope Vein
Transmitter NAA
Station Interval 10M.
Real Component —
Quadrature Component - - -
Direction of Readings →

imaginary%

Real %

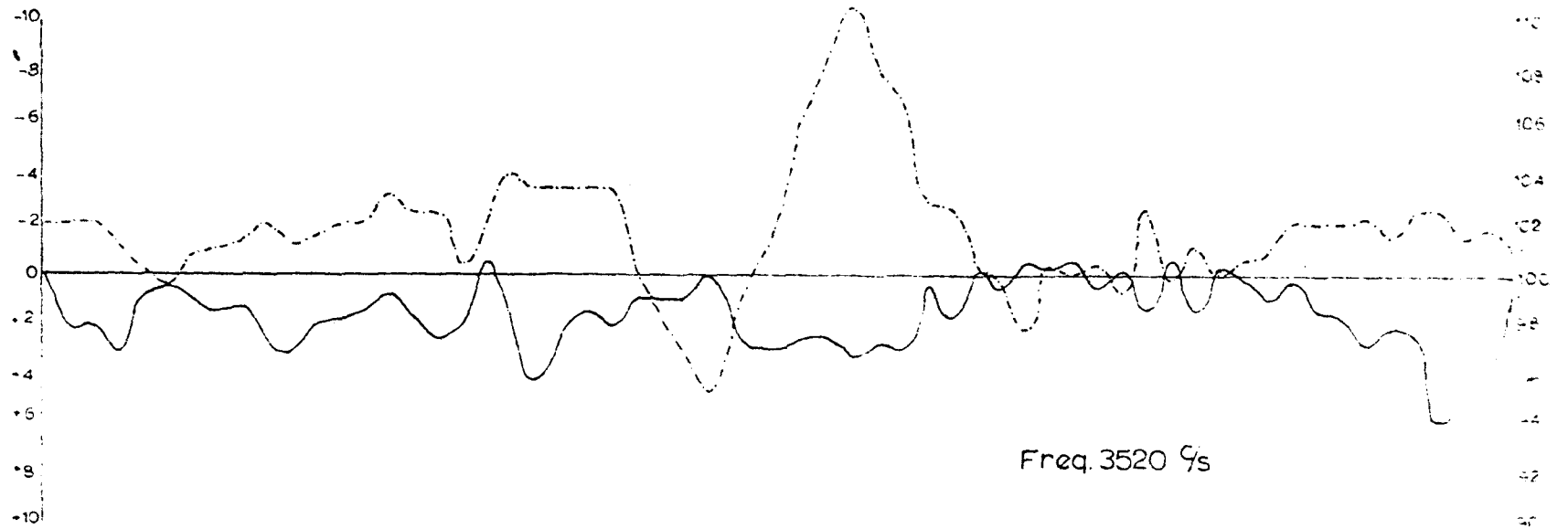

FIG 4

E.M. Traverse over:- The Little Eggeshope Vein.

Coil Separation 60M.

Station Interval 10 M.

Real Component —

Imaginary Component - - -

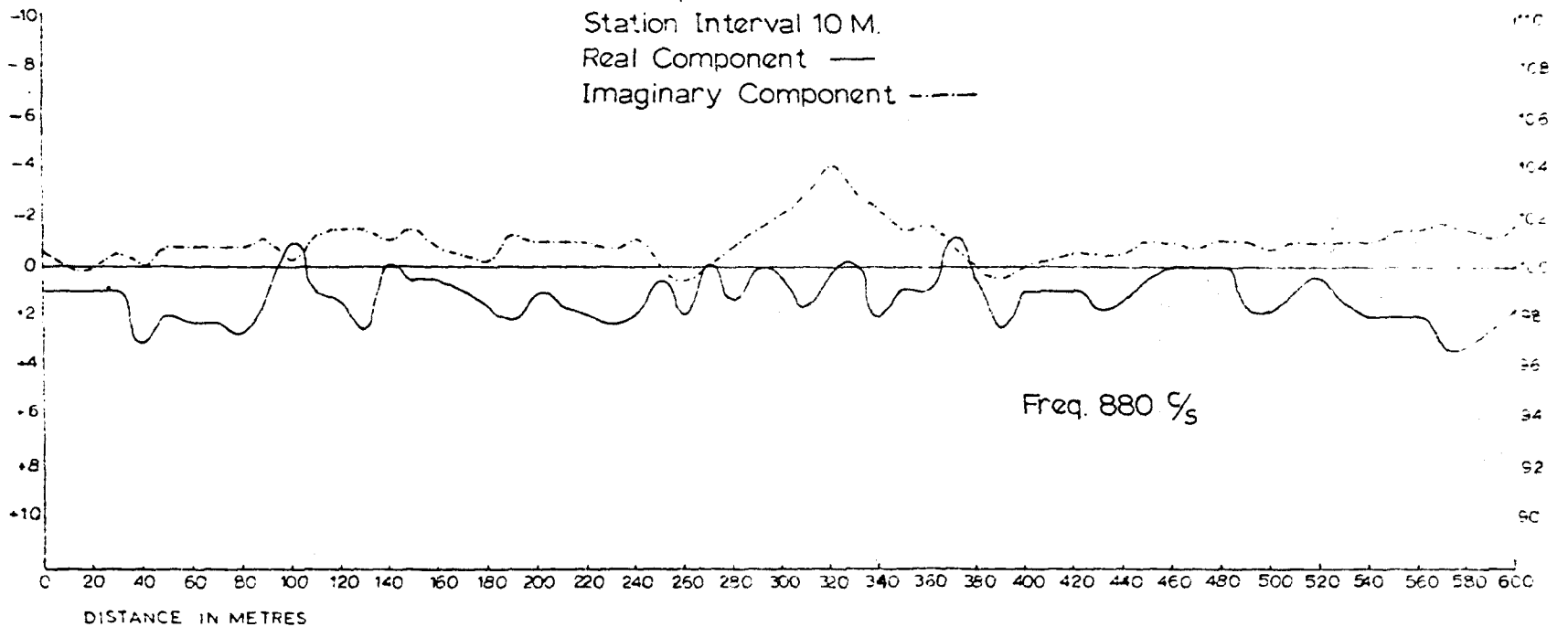

CORNISH HUSH MINE BYPASS DRIFT (GEOLOGY)

1:500

AE.52. - LITTLE EGGLESHOPE.

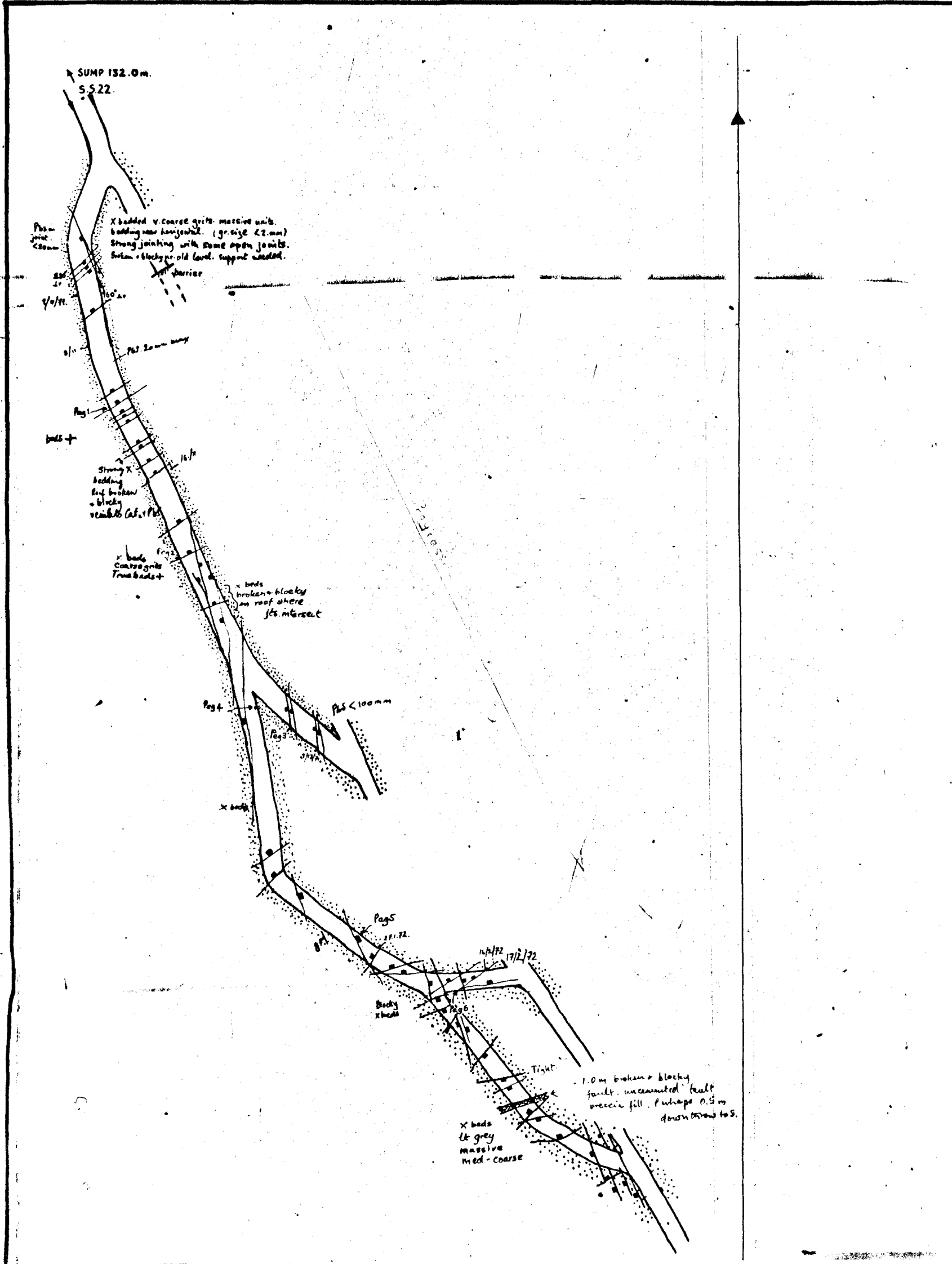

SAMUK.

Cornish Hush Mine. AE 52.

Scale 1:1000

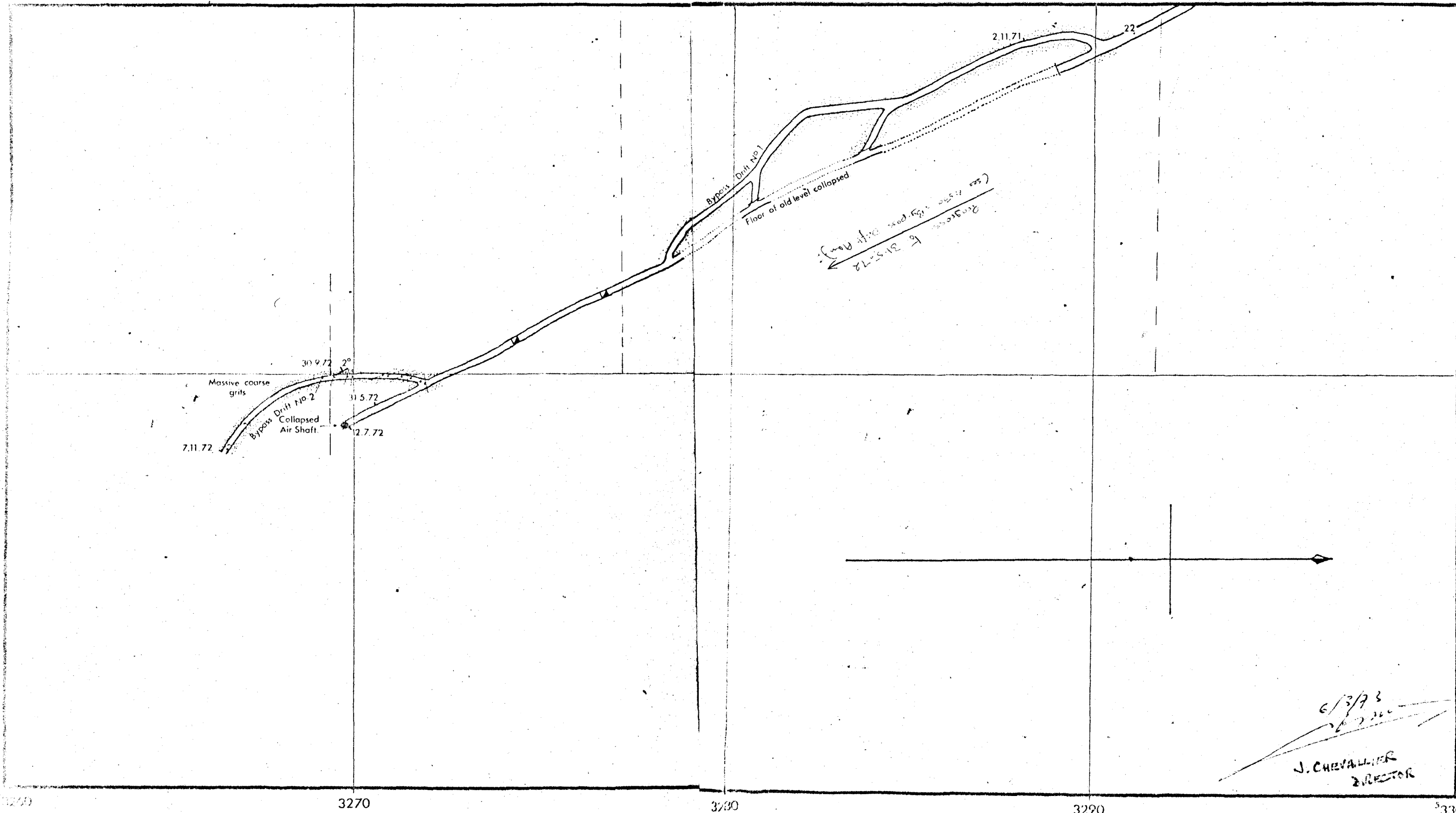

WIREGILL NORTH VEIN
AE 68

LITTLE EGGLESHOPE (CALIFORNIA) VEIN
AE 53
POTTS' VEIN

WIREGILL SOUTH VEIN

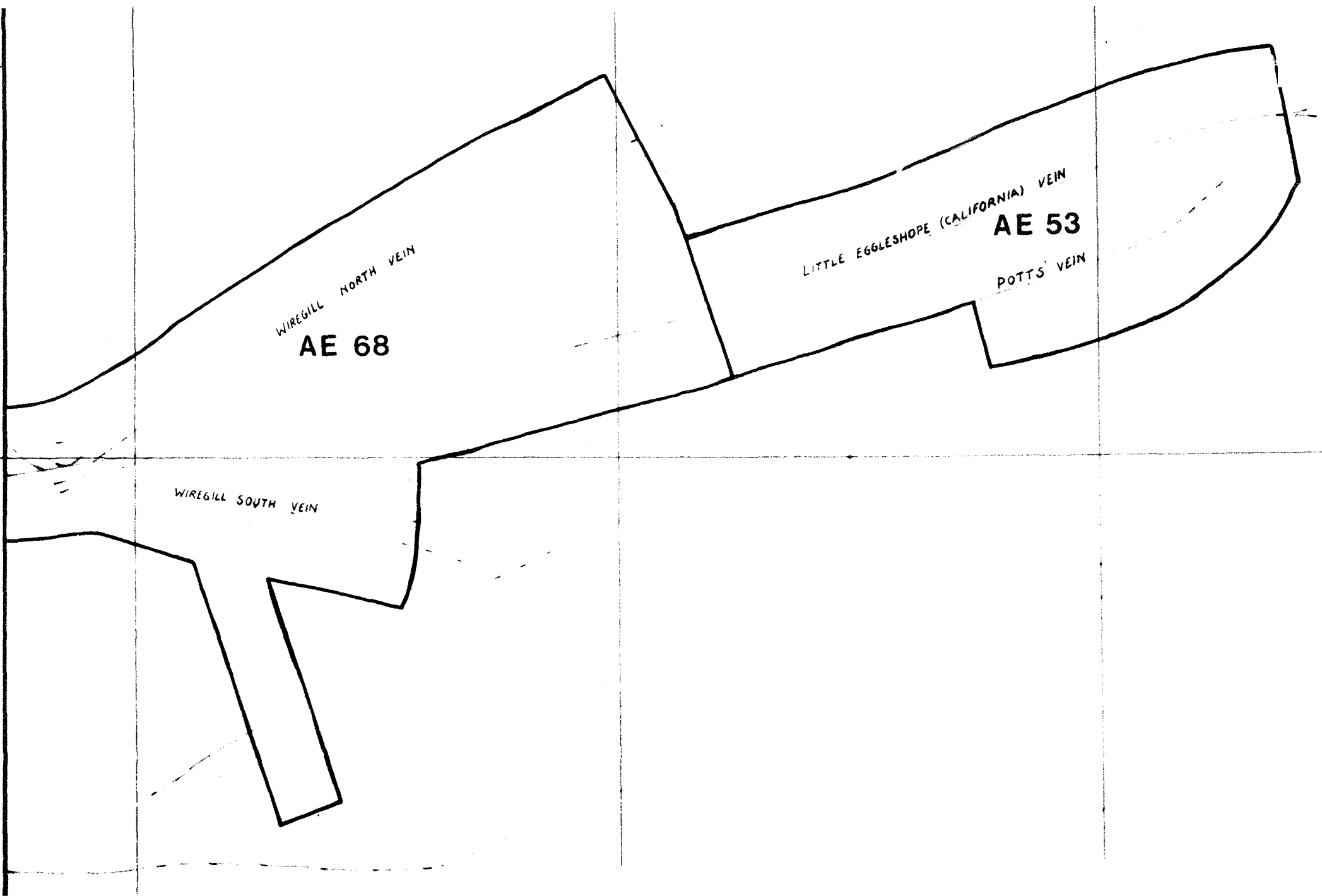

SWISS ALUMINIUM MINING (U.K.) LTD.

EXPLORATION AREAS AE 51, 52 & 53. [TEESDALE]

D.T.I. Ref: MME /AE 51-53.

SAMUK Ref: BB-PW/gh.

SCALE 1 :10,000

Drawn by G Hughes
16 5 72

OPERATIONS LIMITED HORIZONTALLY TO
150m ON EACH SIDE OF VEINS AND 60m
ABOVE or BELOW THE EXPLORATION LEVELS
IN THE SHADED AREA ALL WORKS ON
SHARNBERRY NORTH VEIN WILL BE CHARGED
TO AE 51; WORKS ON OTHER VEINS WILL
BE CHARGED TO AE 52.

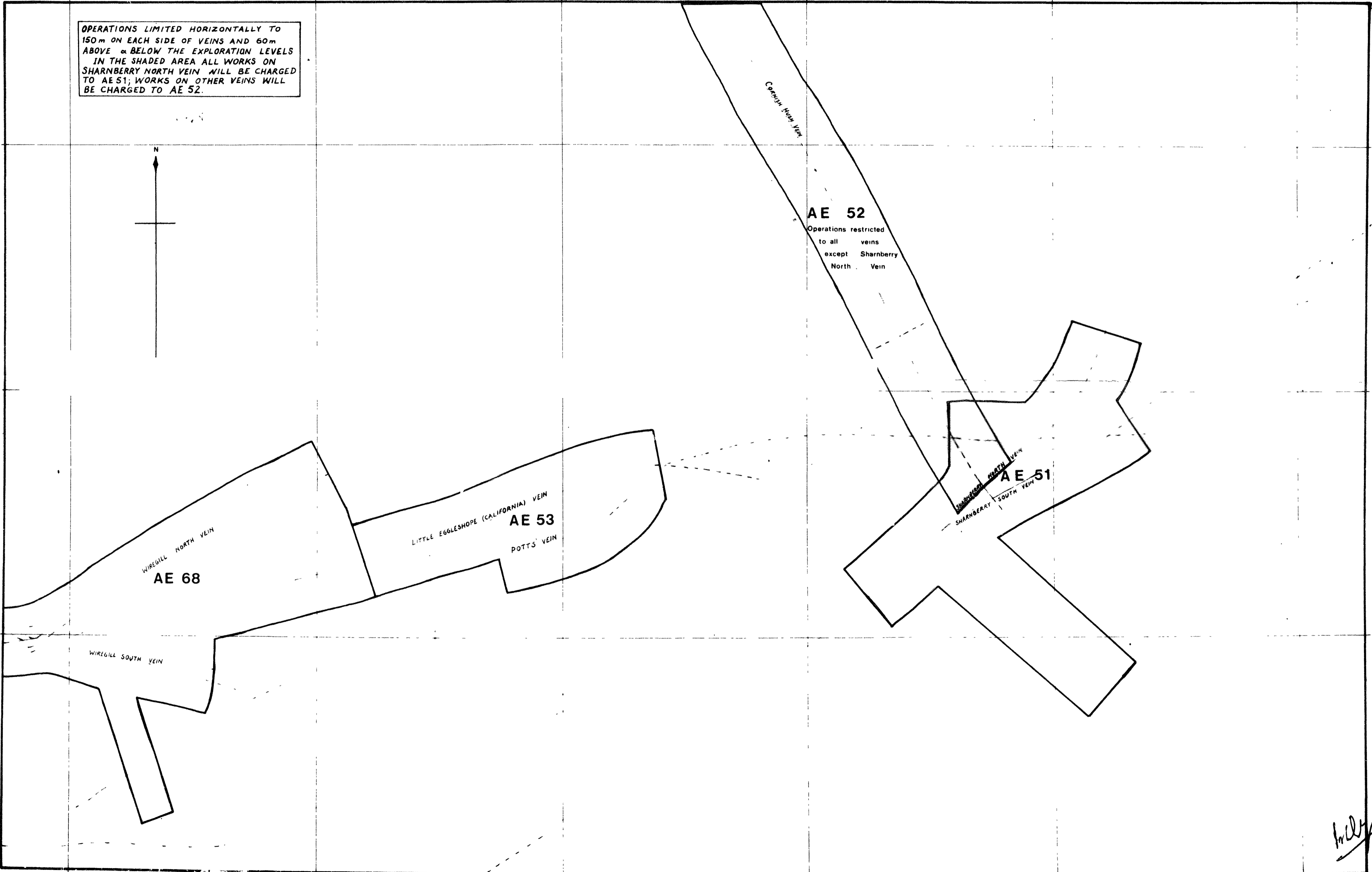

Incl...

0 5 Grid Co-Ordinate

98°

99°

00°

01°

02°

34°

34°

33°

33°

32°

32°

31°

31°

↑
STANHOPE

LEVEL

NO WREN
LOW LEVEL

BLACK BURN

SHAFTWELL SIVE

RES.

BASE OF OPERATIONS FOR AREA 2

AREA 2

LITTLE EGLESHOPE

CORNISH HIGH AIR SHAFT
APPROX. F.H. LOW LEVEL
CORNISH TUSH Vn.

F.H. SHARBERRY HIGH LEV.

APPROX. F.H. HIGH LEVEL

LITTLE EGLESHOPE VEIN ACCORDING TO GEN. SURV. 1855
SOUND & RECORDED WITH
L. G. GARDNER'S SURV. 1855
DATE ESTIMATED AS 165
ON E. S. CORNER OF
LITTLE EGLESHOPE.

AREA 3
CALIFORNIA

AREA 1
SHARBERRY

AREA 4
WIREHILL

LITTLE EGLESHOPE VEIN

BASE OF OPERATIONS
AREA 3

RESERVOIR

RESERVOIR

BASE OF OPERATIONS
AREA 4

BASE OF OPERATIONS FOR AREA 1
SHARBERRY LOW LEVEL 1210' AOD

SCALE - 8 CHAINS TO AN INCH

-JES- NOV. 1970

02°

01°

00°

99°

98°